

80050

Modellname / Model name / Nom du modèle / Modellnamn
 Nome modello / Název modelu / Modelnaam / Ime modela
 Numéro Modèle / Modell neve / Название модели /
 Názov modelu / Ime modela / Denumire model /
 Наименование на модела / Nazwa modelu

TIGO

Type / Tipo / Tipus / Тур / Тип / Tip

60 2S

Farbe / Color / Couleur / Kolor

EVOKE

20.05.2025

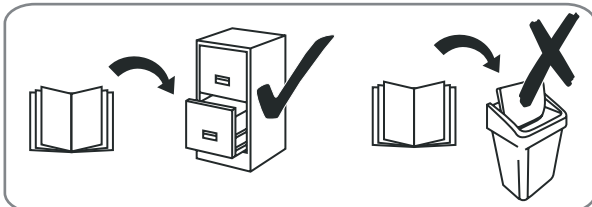
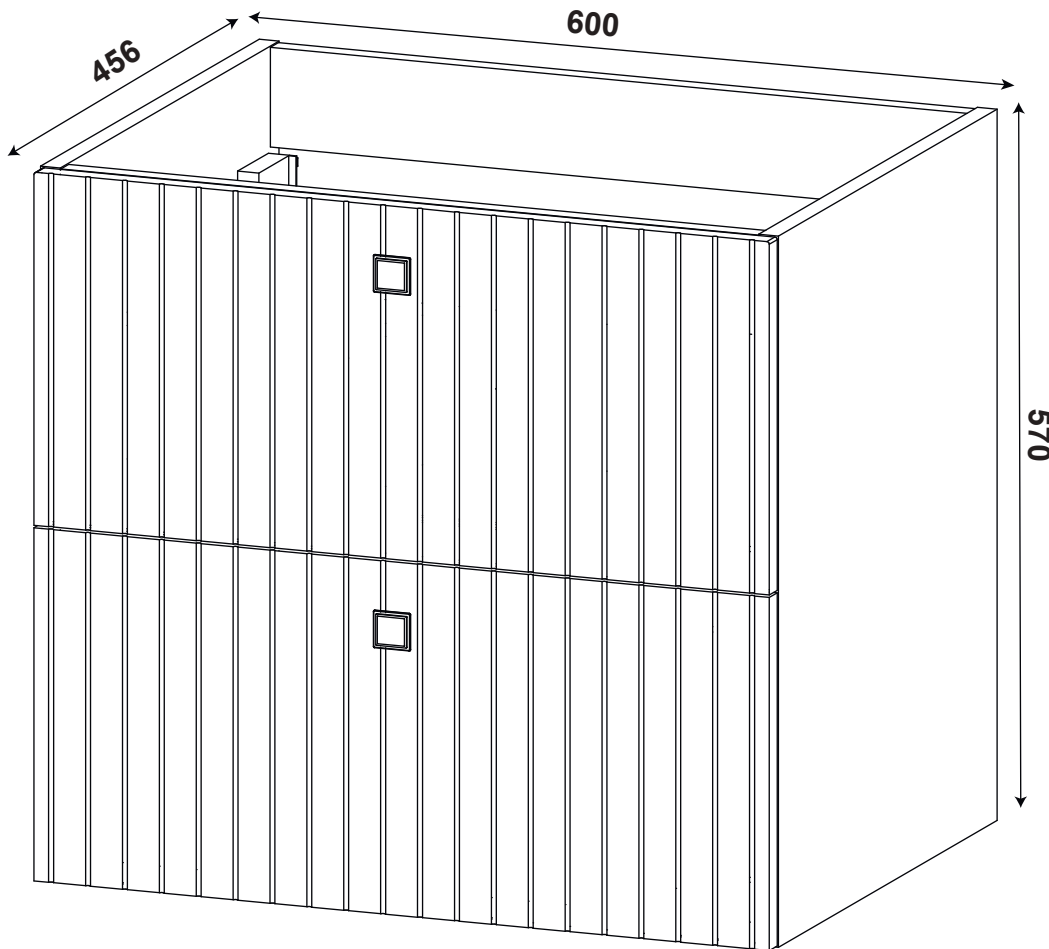
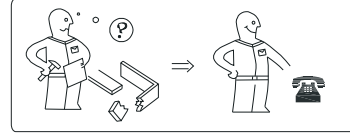
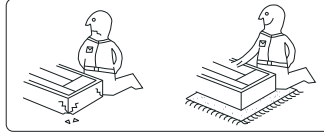
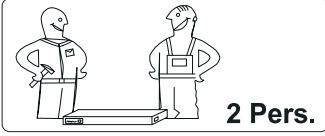

**Wichtig - Für spätere Verwendung
 aufbewahren - sorgfältig lesen!**

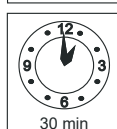
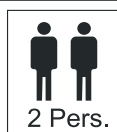
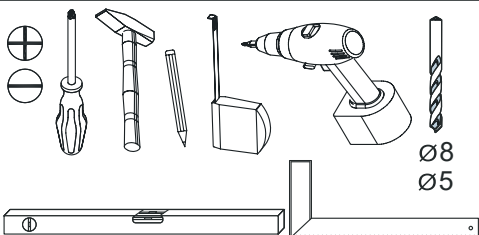

festziehen / tighten / Затягнeтe /
 serrer / stringere / utåhñout / vasttrekken /
 zategnuti / sřrångere / zwiázac / zaciñac /
 szorosan meghúzni / pevne dotiahnut /
 trdno pritegniti / зятянуть / dra át



eindrücken / press in / enfoncer / wcisñac /
 ribattere / zallaçit / Вкарáйтe / indrukken
 benyomni / sřlacit / vtisñiti / truck in
 introducere prin apårare / вдáвить



ausmessen / measure / mesurer /
 misurare / opmeten / izmeriti / miara /
 kimérni / izmereti / mãsurare / измерить
 změřit / Измеретe / mät upp / zmierzyc



drücken / press / presser / stisknout /
 Hatricñere / vtisñiti / nasinac / drukken /
 pritisniti / nacisñac / pritisñiti / ñažat /
 (meg)nyomni / apasare / truck fast / nacisñac



einschlagen / hammer in / beverni / sla in
 frapper au marteau / infossare / Zabit /
 zarazit / ñabíyt'e / zabiti / wbiç
 introduce prin bãtaie / забить / zatlout



Drehen - wenden / przekręciç - odwróciç /
 Keren - omdraaien / Girare - Ruotare /
 Okrenuti - ubrnuti / Retourner - renverser /
 Turn over - turn around / Otoçte - obratit'e /
 Závъртете - обвъртете / Obrnite list /
 întoarçeti - rotiti / Vrid runt - vänd /
 прокрутить - повернуть / otoçit - obrátit
 elforgåtni - megfordítani

Modell name/Model name/Nom du modele/Modellnamn
Nome modello/Název modelu/Modelnaam/Ime modela
Número Modelo/ Modell neve/ Название модели /
Názov modelu/Ime modela/Denumire model/
Наименование на модела /Nazwa modelu

TIGO

Type / Tipo / Tipus / Тип / Тип / Tip

60 2S

Farbe / Color / Couleur / Kolor

EVOKE

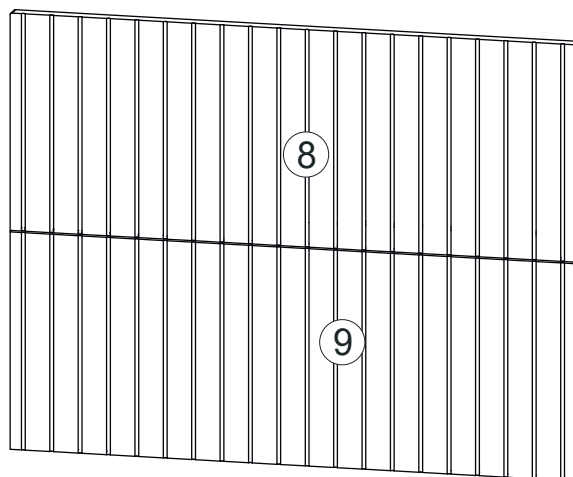
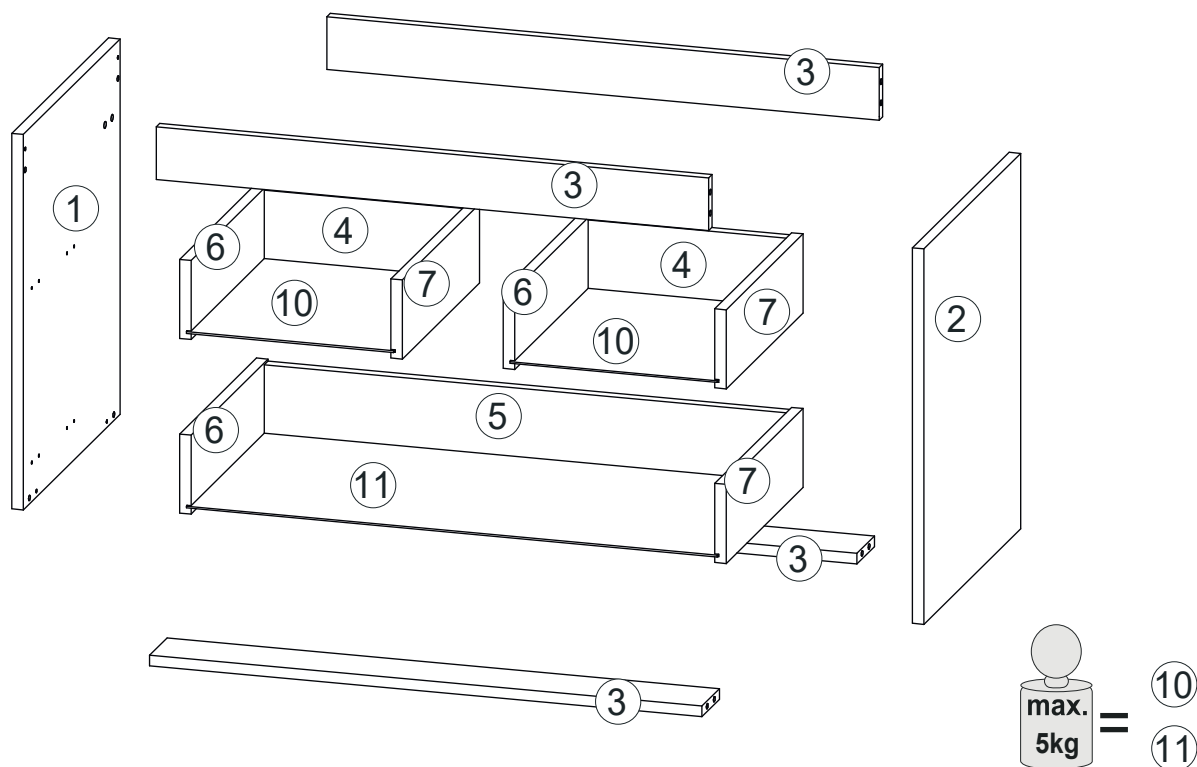

Nr.	Maße mm			Colli	Anzahl
1	570	440	16	1/1	1
2	570	440	16	1/1	1
3	568	80	16	1/1	4
4	178	104	16	1/1	2
5	528	104	16	1/1	1
6	350	120	16	1/1	3
7	350	120	16	1/1	3
8	283	598	16	1/1	1
9	283	598	16	1/1	1
10	188	354	2,5	1/1	2
11	538	354	2,5	1/1	1
B1				1/1	1

Modell name/Model name/Nom du modele/Modellnamn
 Nome modello/Název modelu/Modelnaam/Ime modela
 Numéro Modelo/ Modell neve/ Название модели /
 Názov modelu/Ime modela/Denumire model/
 Наименование на модела /Nazwa modelu

TIGO

















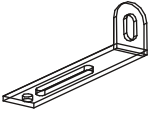

Type / Tipo / Tipus / Typ / Тип / Тип

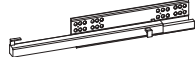
60 2S

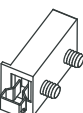
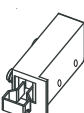
Farbe / Color / Couleur / Kolor

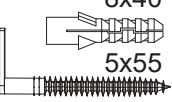

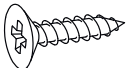
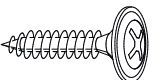

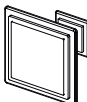
EVOKE

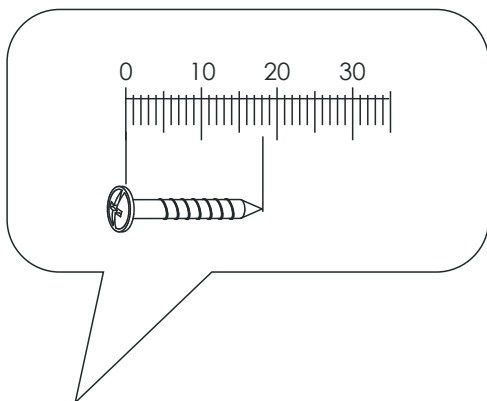
B1

 Ø20 C0/11 x14	 C2 x14	 C7 x14	 Ø12 B0/3 x12	 6,4x50 B1 x12	 K x1
 Ø8x30 A0/1 x14	 5x50 8x50 E0 x2	 P0 x2	 L-350 N14L x2	 L-350 N14R x2	 4x30 D13 x4
 «L» P98/4 x1	 «R» P98/3 x1	 5x13 D21 x16	 8x40 5x55 E1 x2	 M1 x6	 4x20 H11 x2
 3,5x16 D5 x12	 3,5x16 D36 x16	 L-350 P93 x1	 L150 x2		

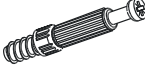
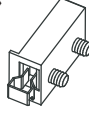

1

 C2 x4	 «L» P98/4 x1	 4x30 D13 x2	 5x13 D21 x8	 L-350 N14L x2
---	---	--	--	--

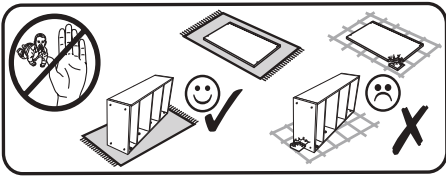
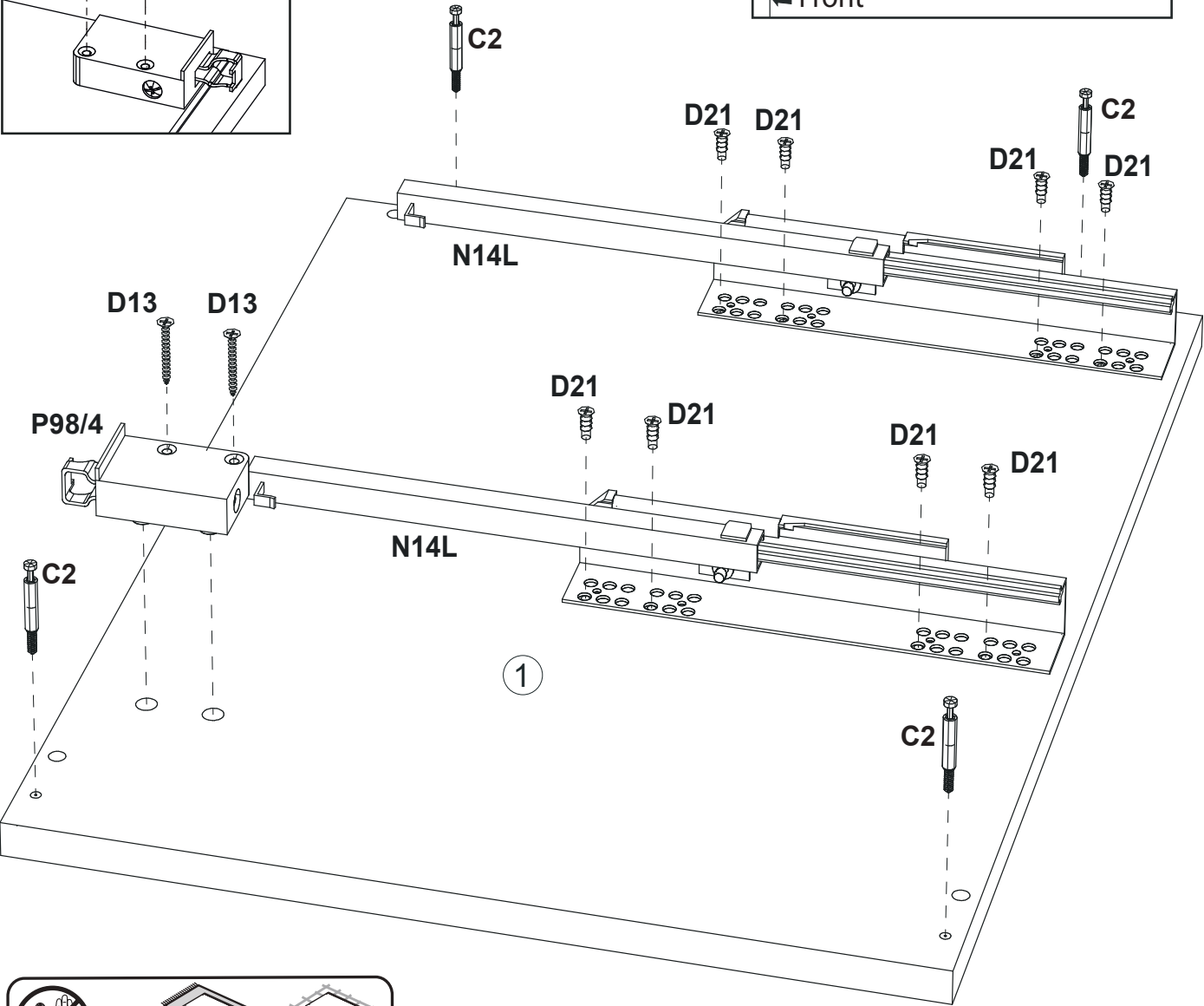
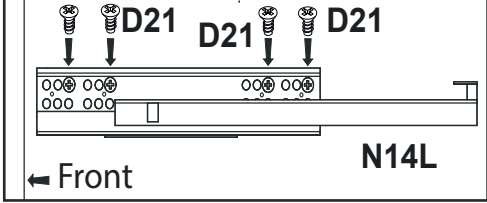
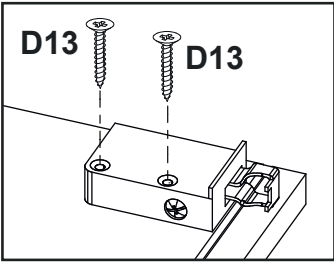
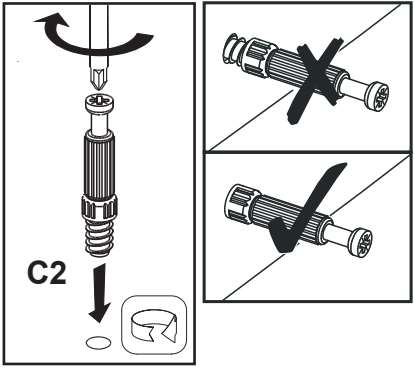
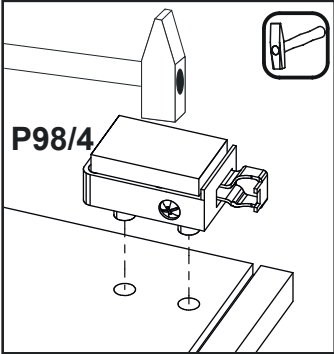

3

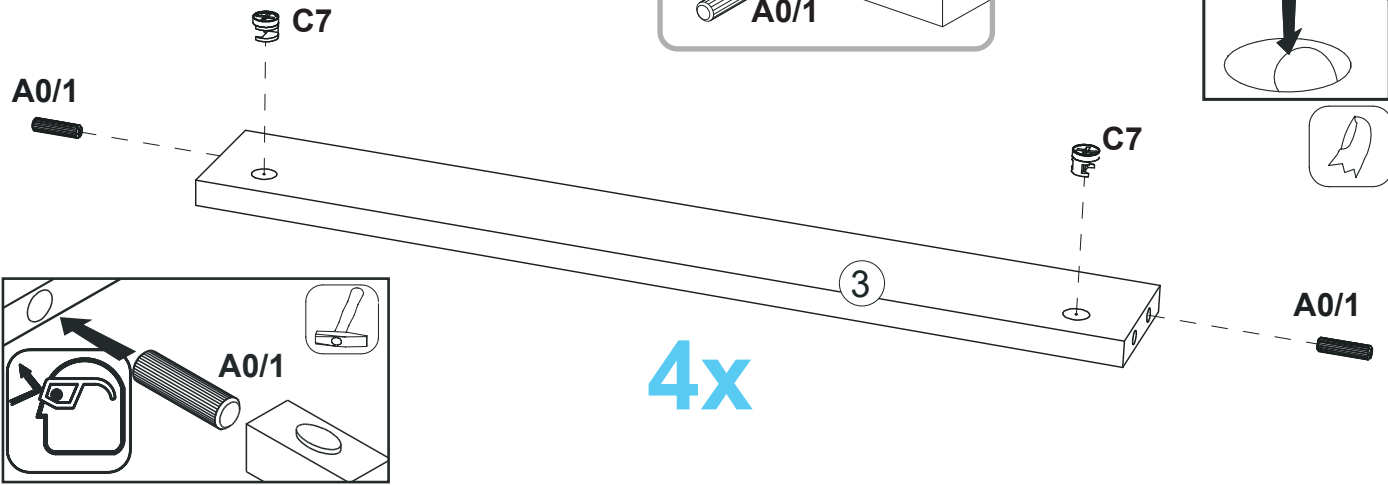
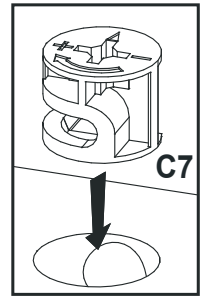
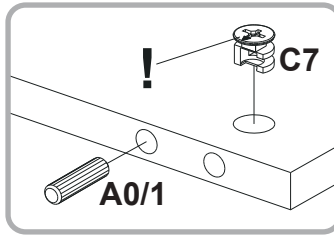
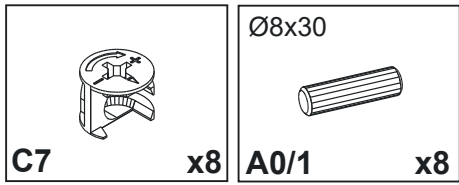

4

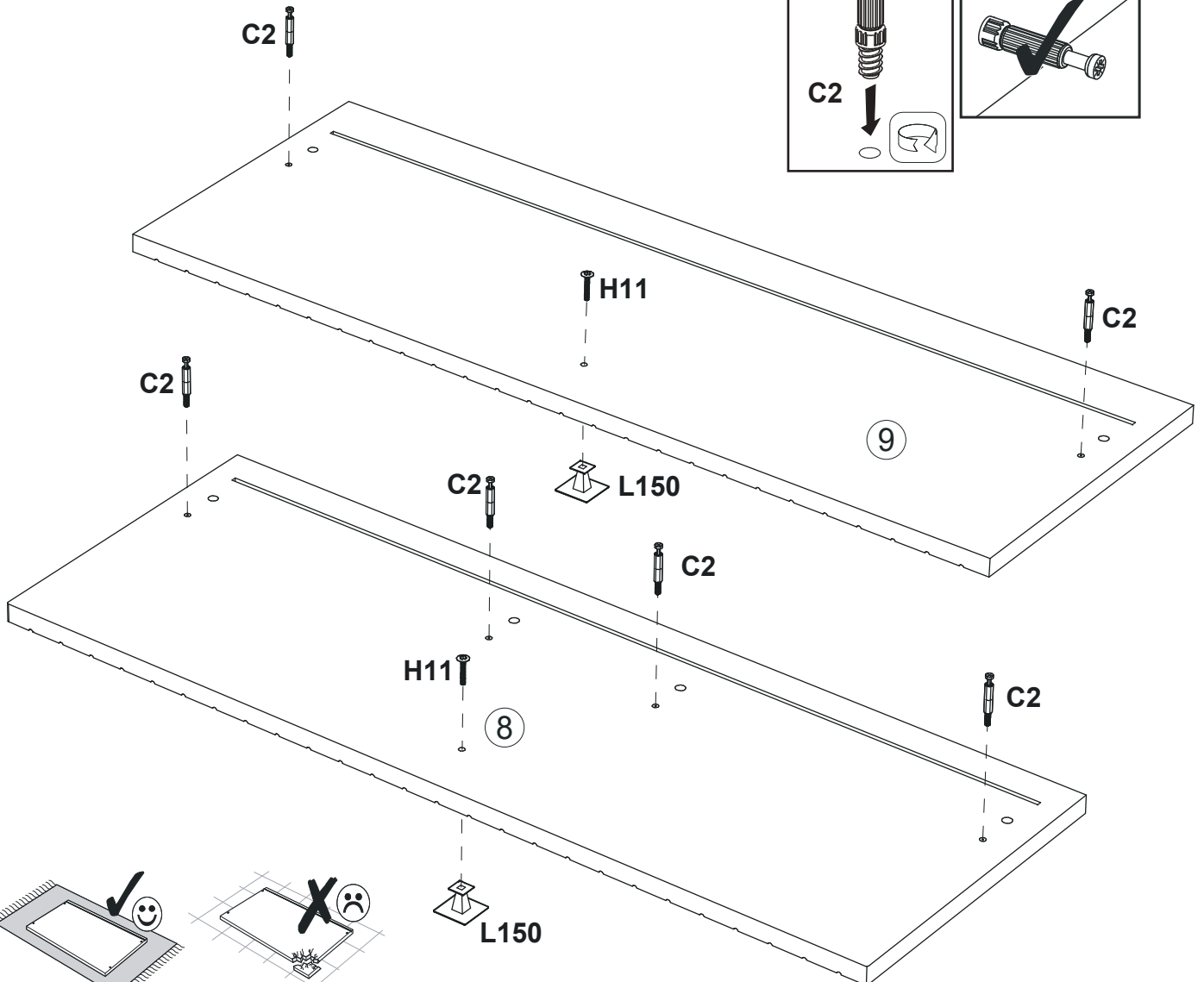
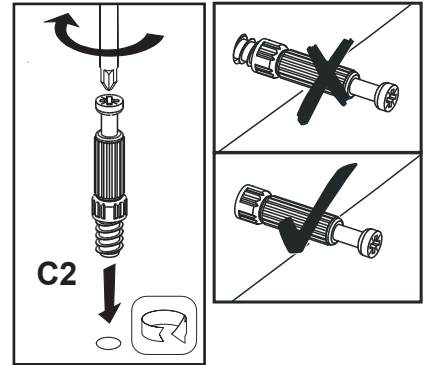
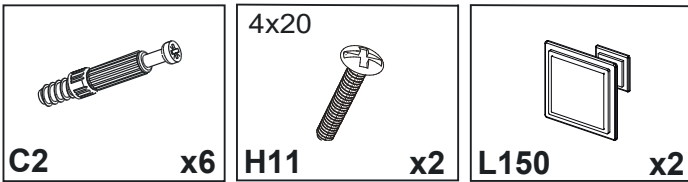

5

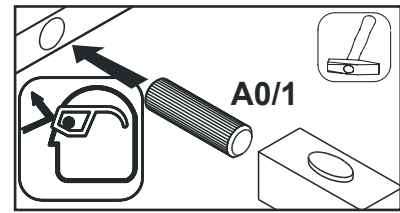
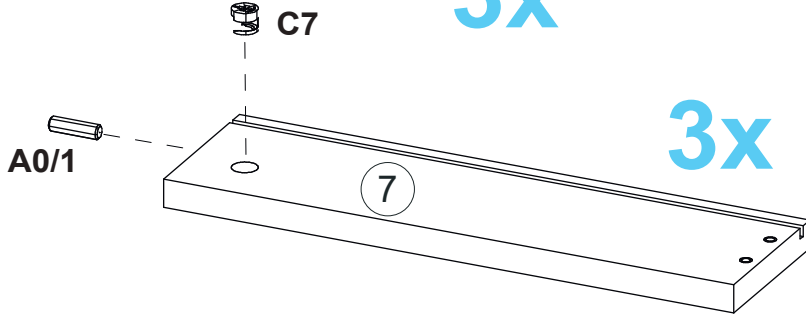
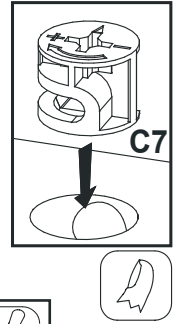
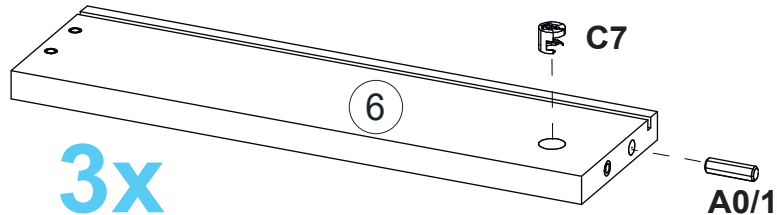
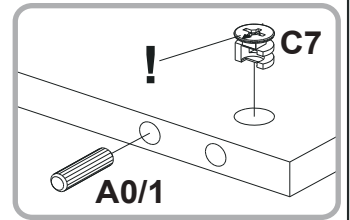
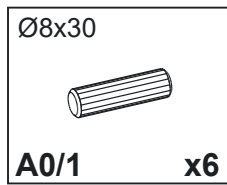
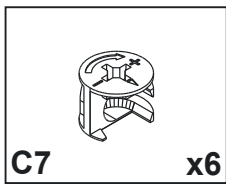

6

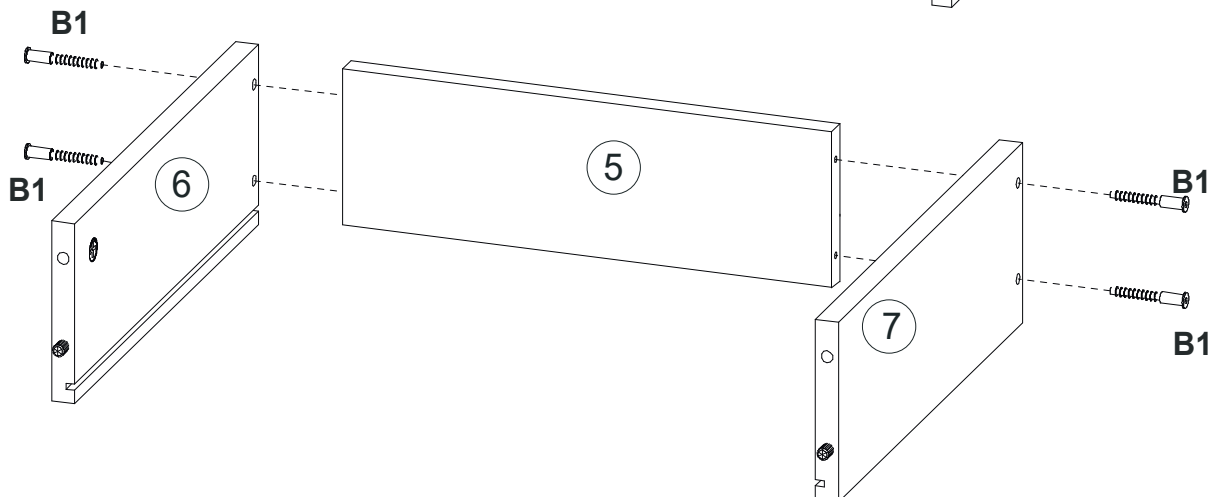
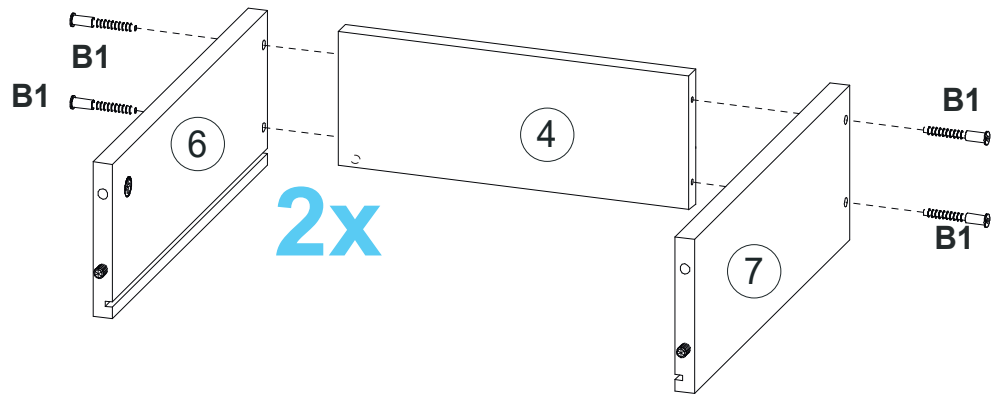
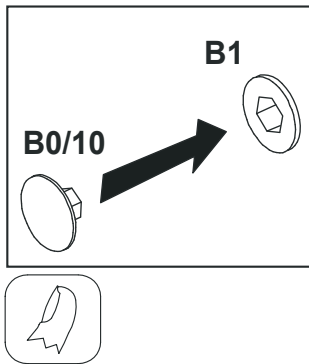
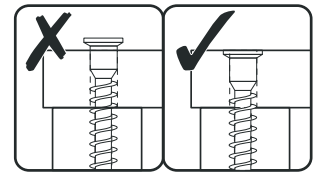
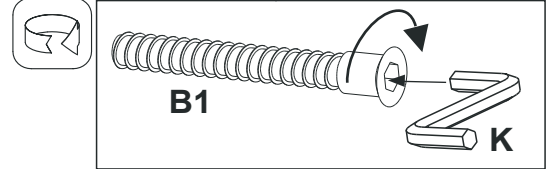
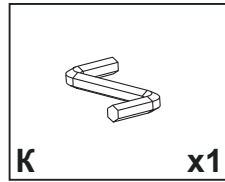
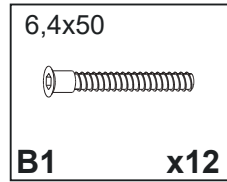
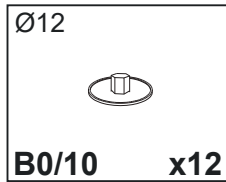

7

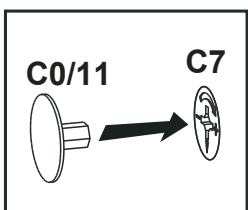
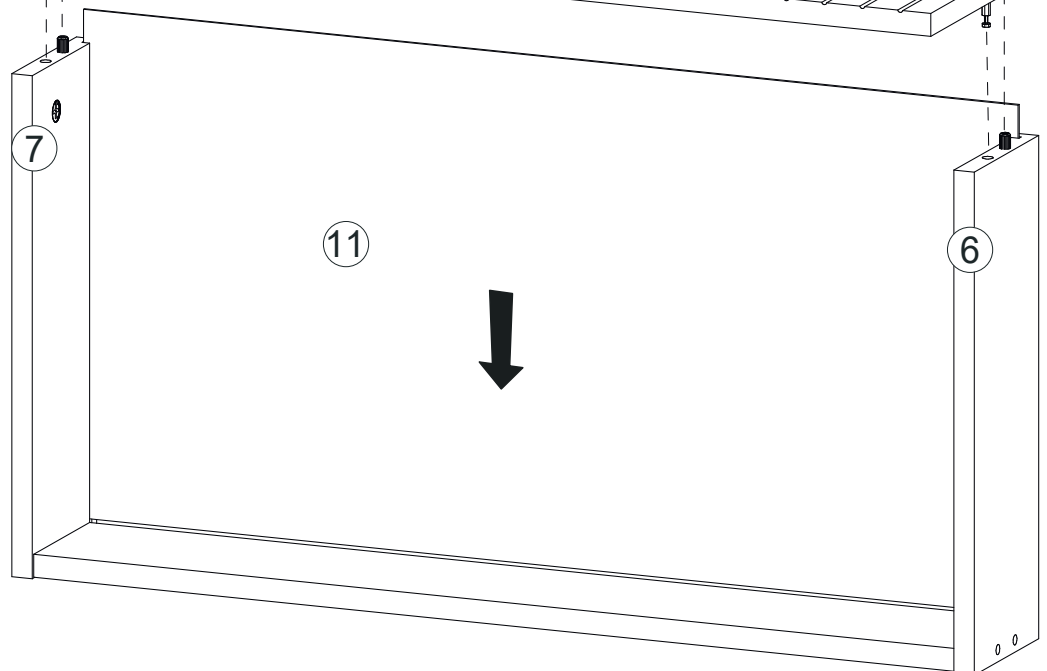
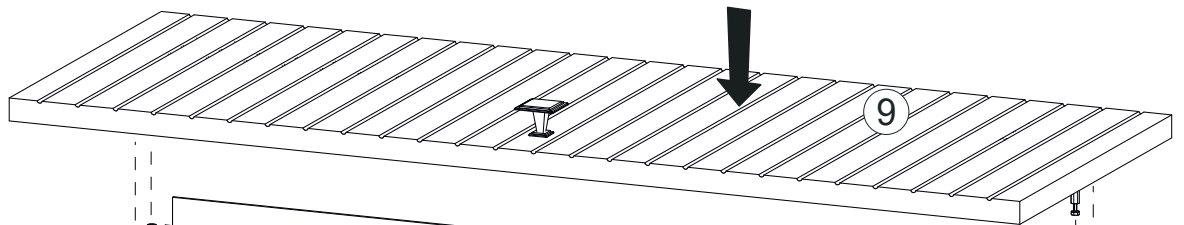
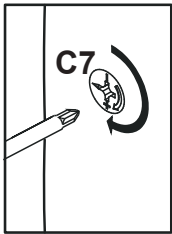
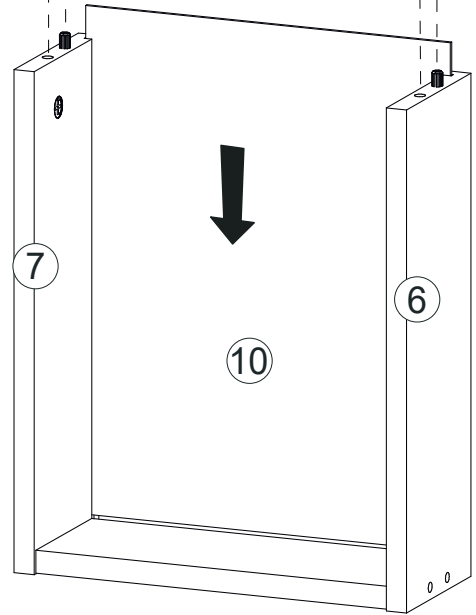
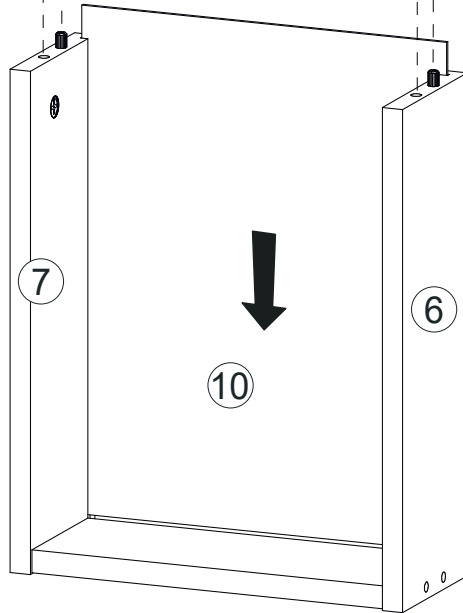
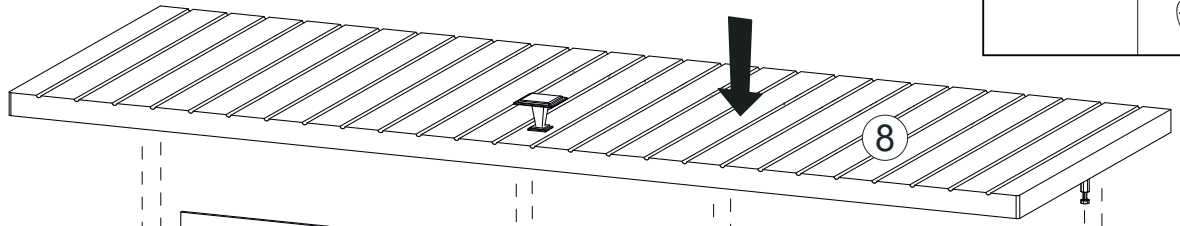
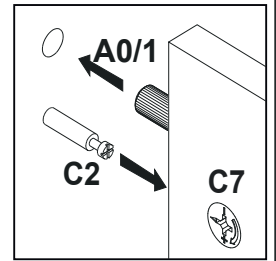
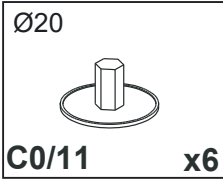

8

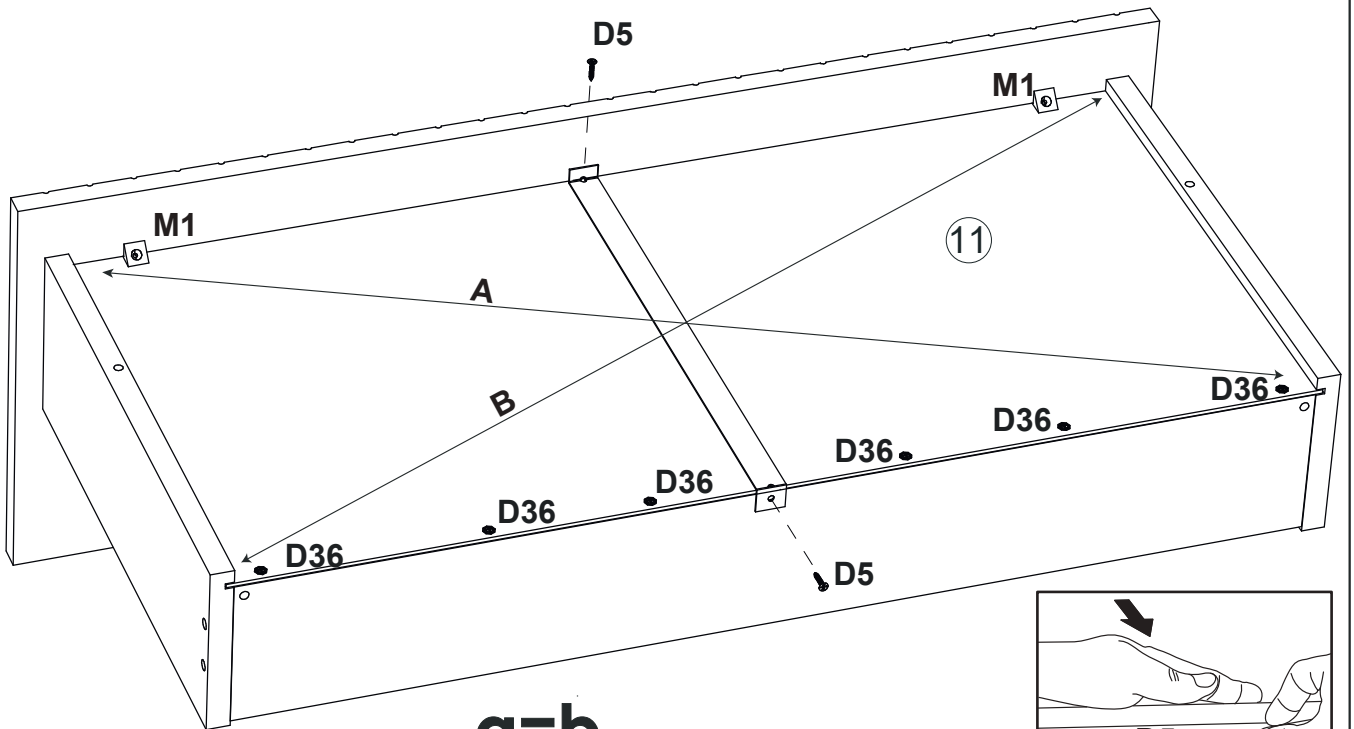
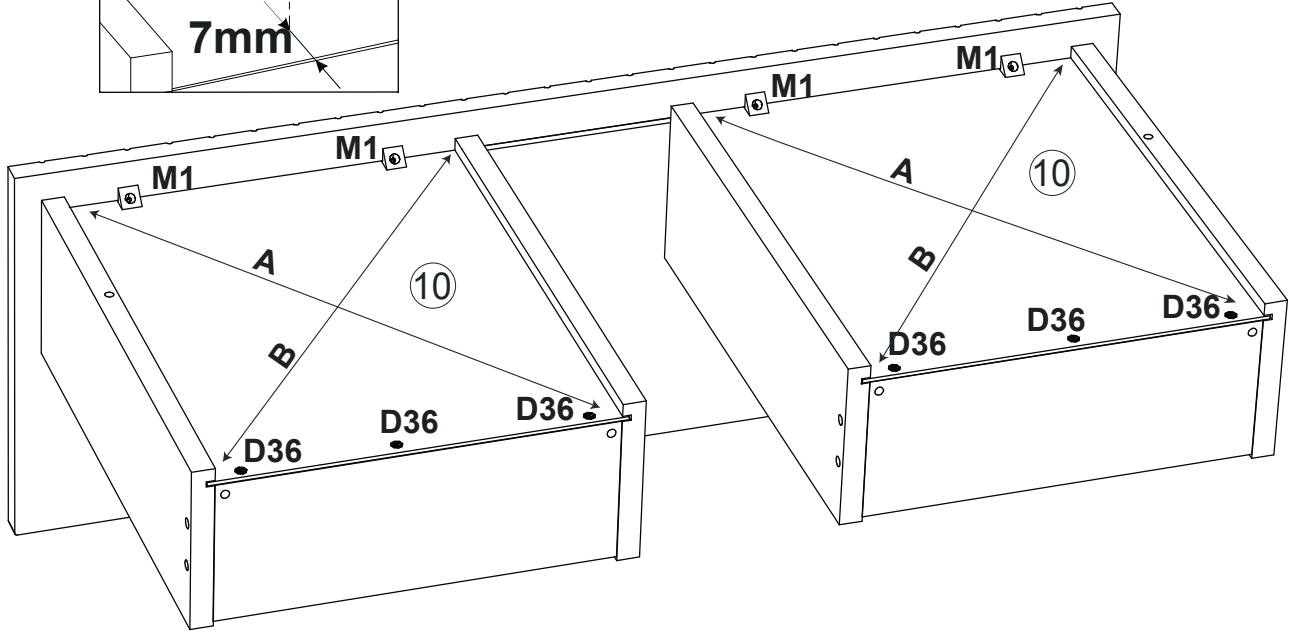
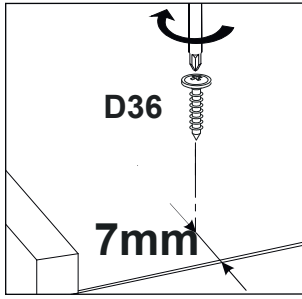
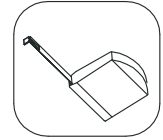
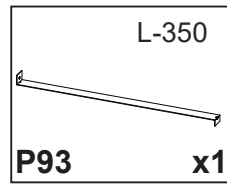
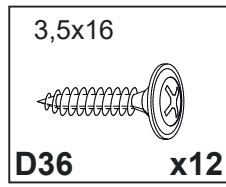
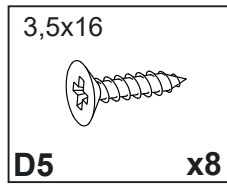
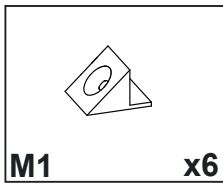

$a=b$

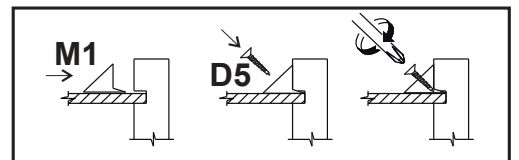
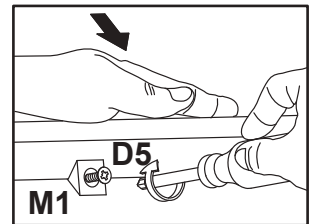
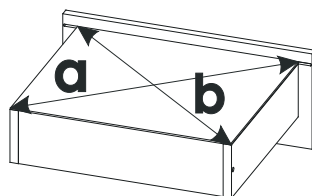

9

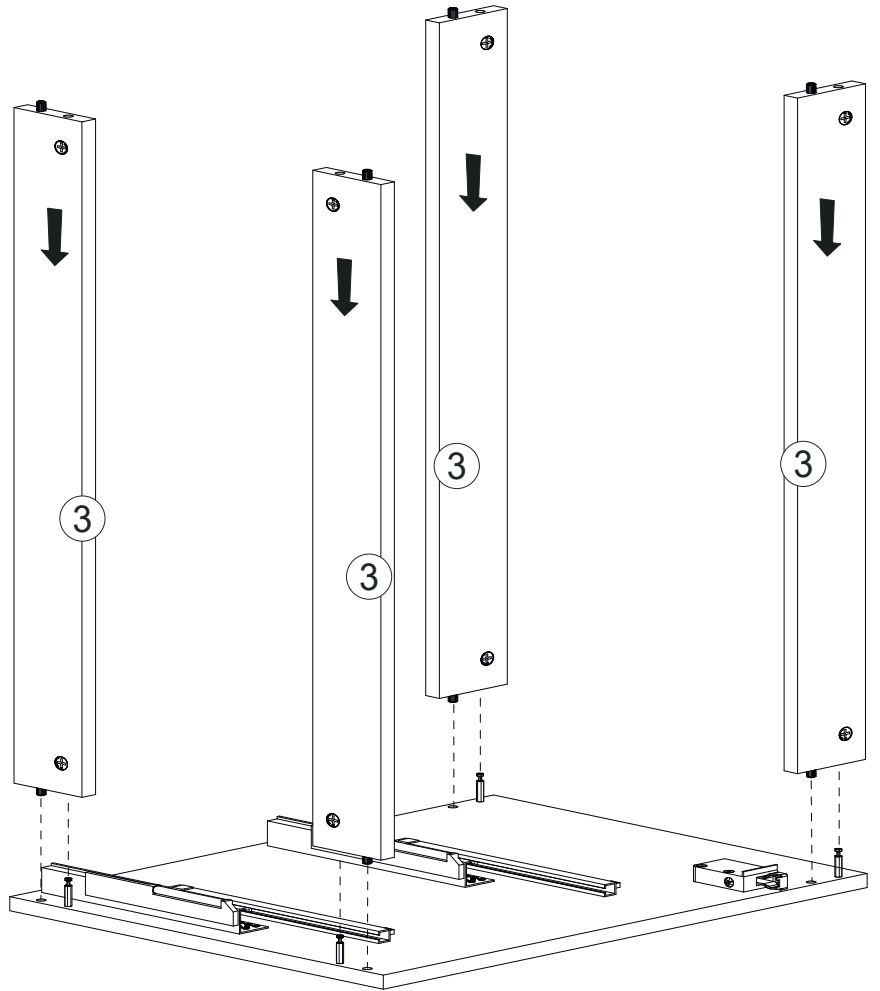
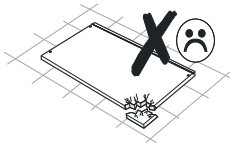
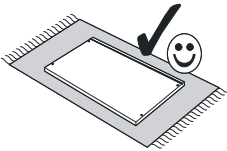
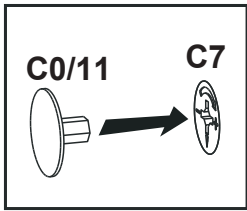
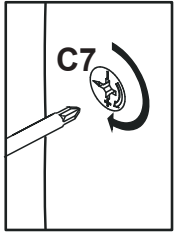
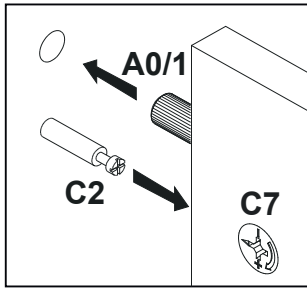
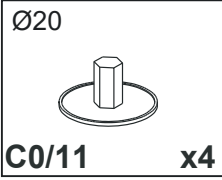

10

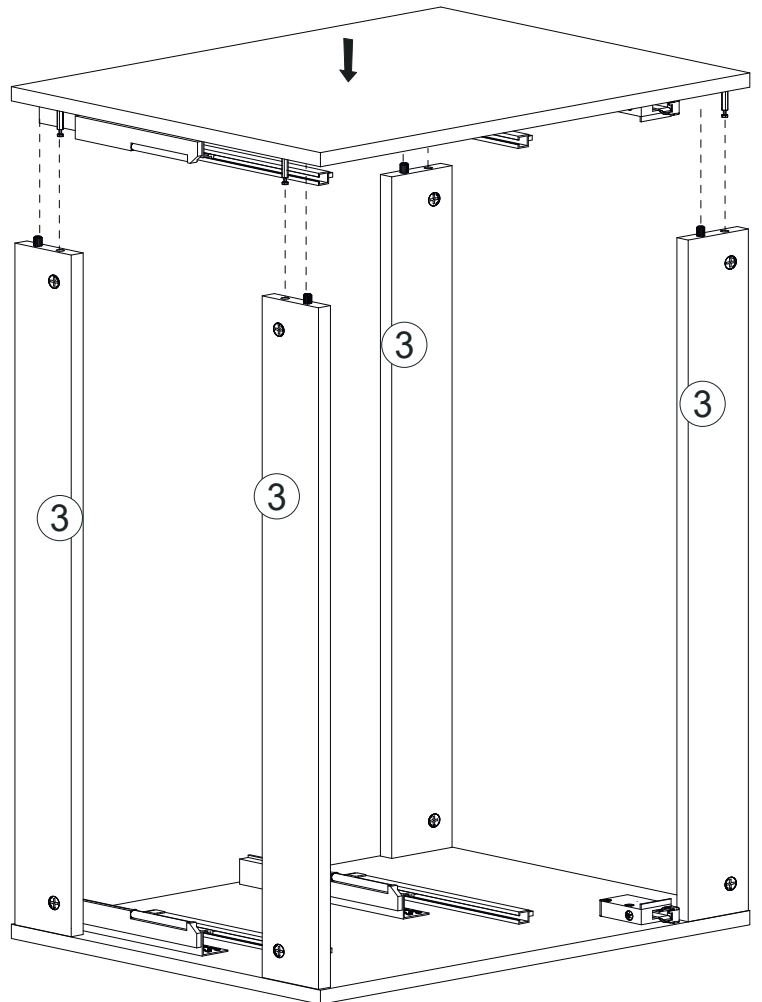
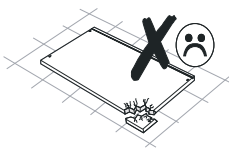
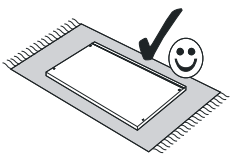
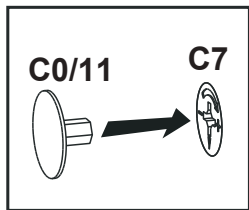
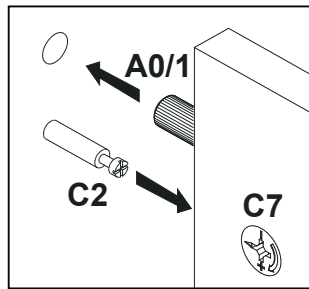
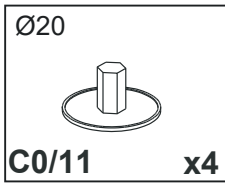

11

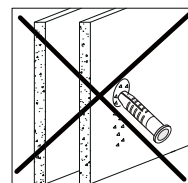
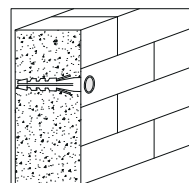
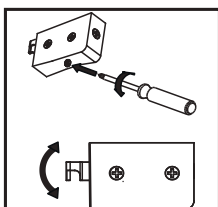
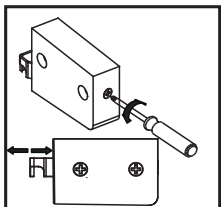
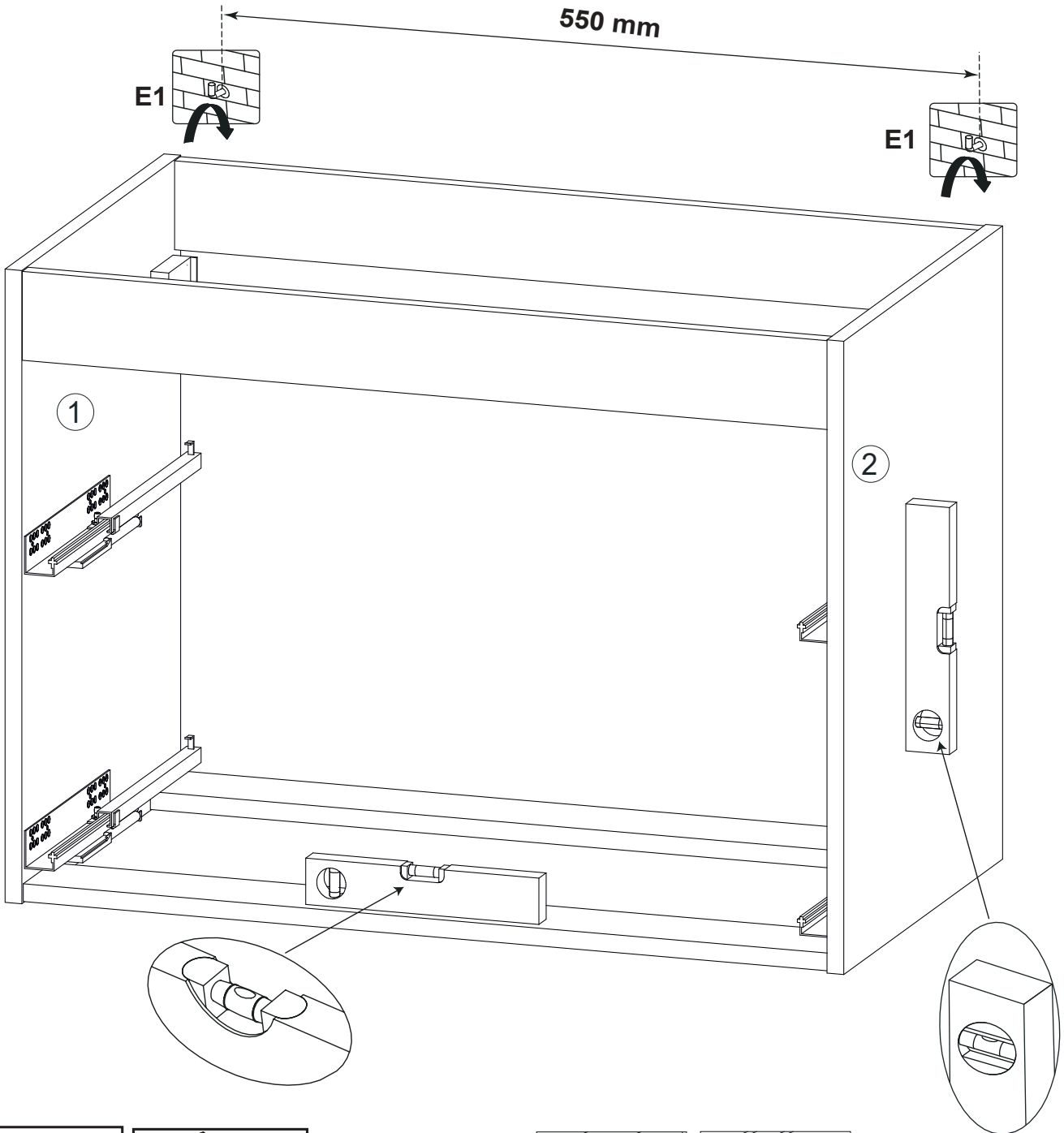
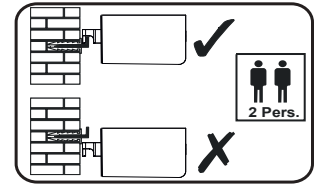
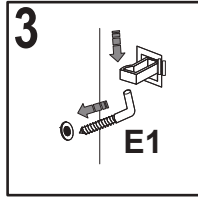
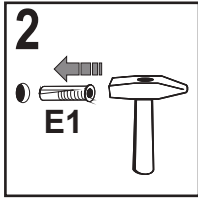
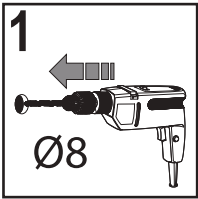
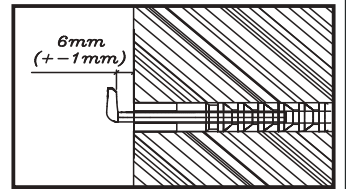
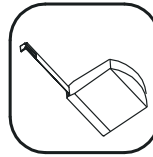
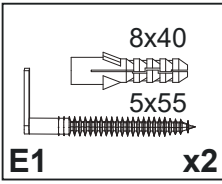

12

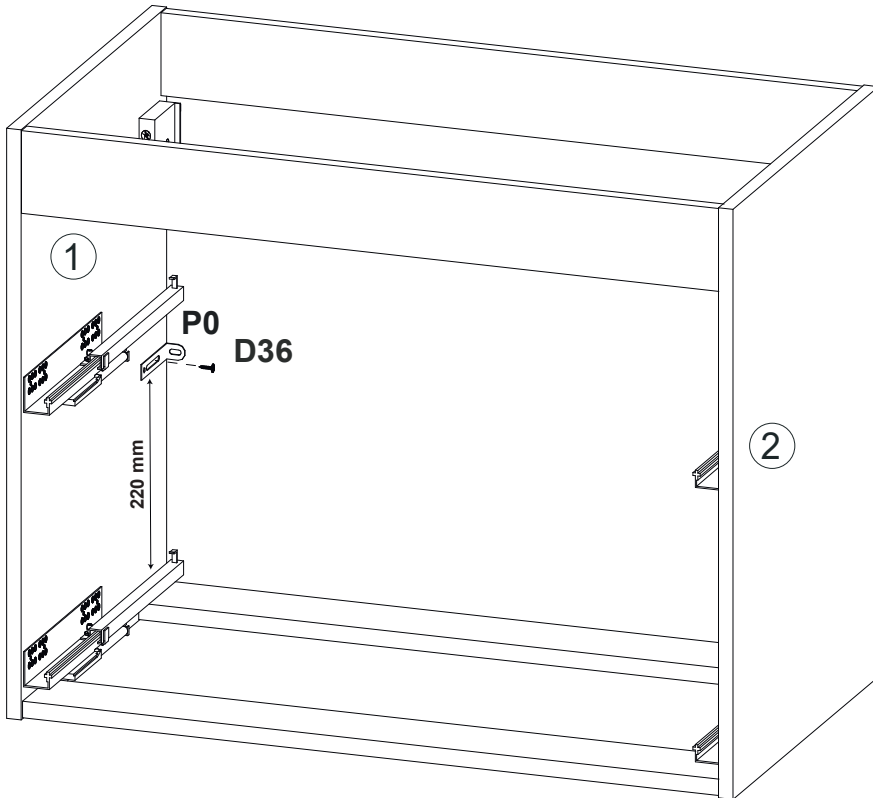
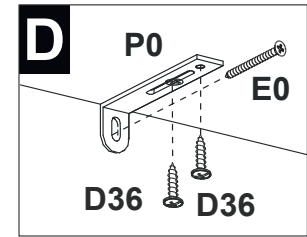
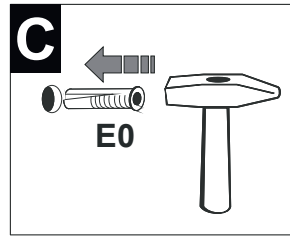
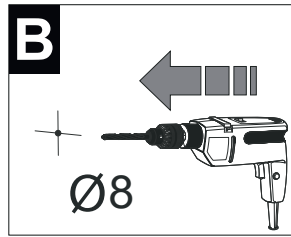
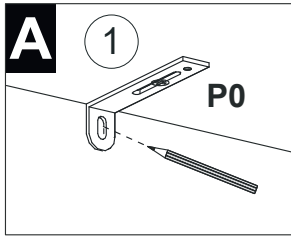
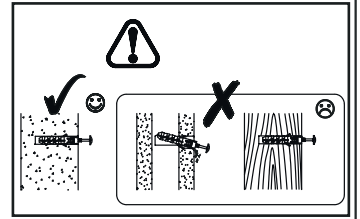
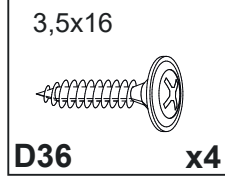
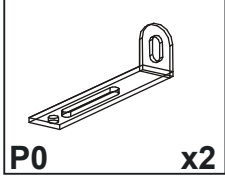
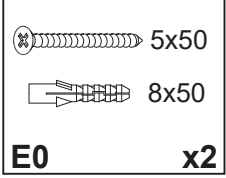

«I.»

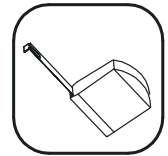

«II.»

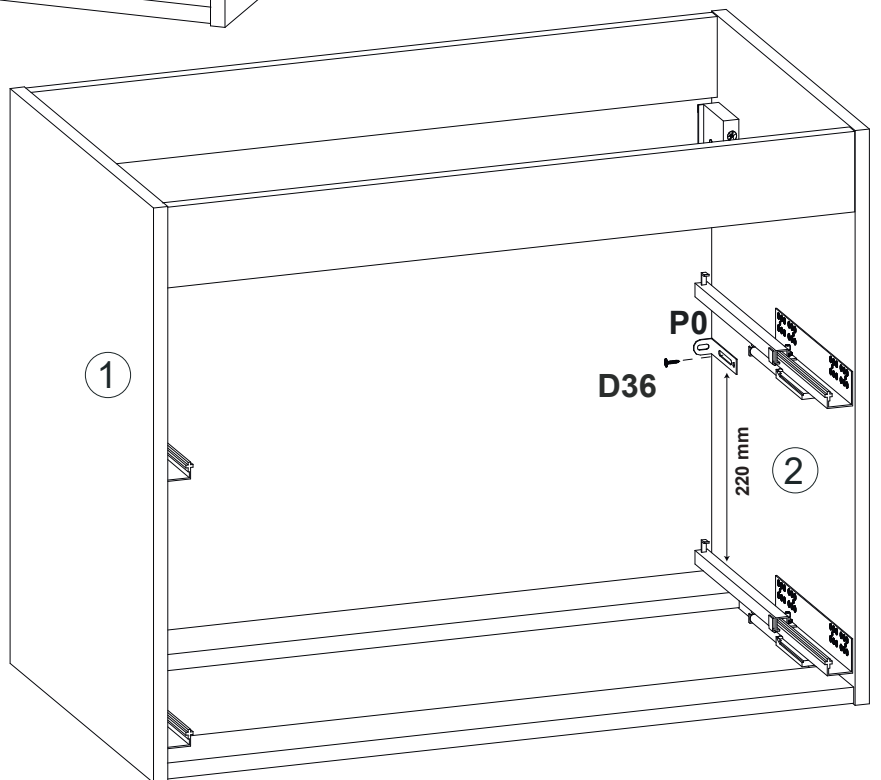
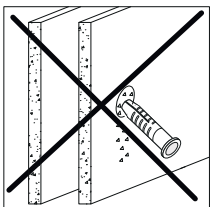
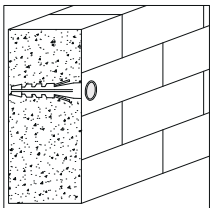

13

3,5x16

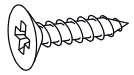

D5 x4

