

80050

Modellname / Model name / Nom du modèle / Modellnamn  
 Nome modello / Název modelu / Modelnaam / Ime modela  
 Numéro Modèle / Modell neve / Название модели /  
 Názov modelu / Ime modela / Denumire model /  
 Наименование на модела / Nazwa modelu

**TIGO**

Typ / Tipo / Tipus / Тур / Тип / Tip

**1D2S**

Farbe / Color / Couleur / Kolor

**EVOKE**

20.05.2025

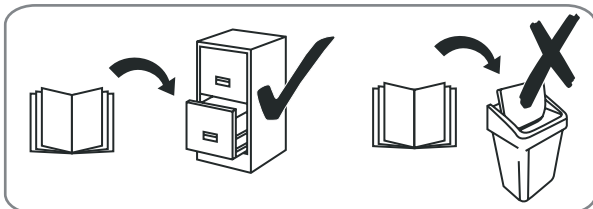
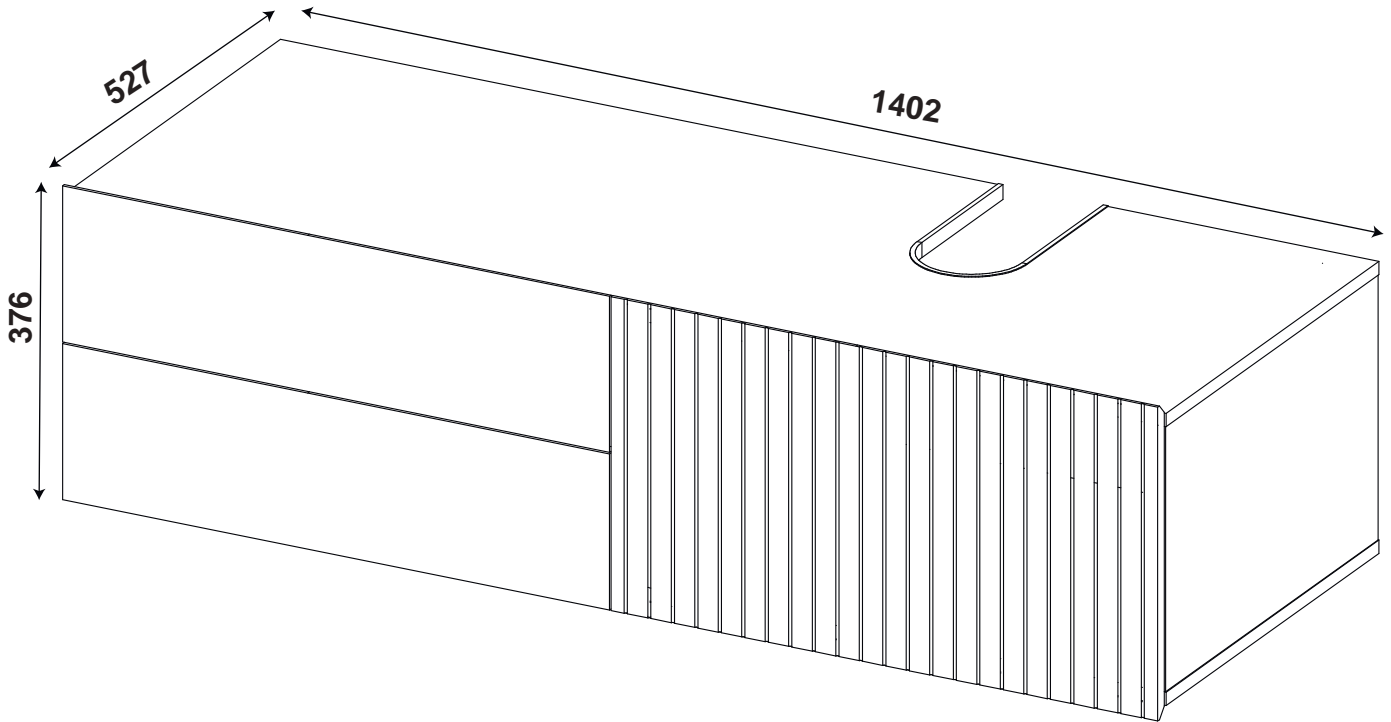
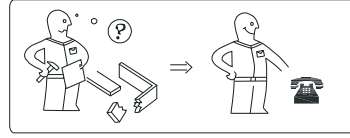
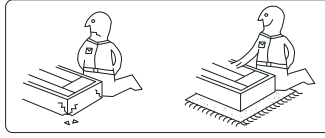
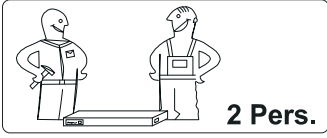

**Wichtig - Für spätere Verwendung  
 aufbewahren - sorgfältig lesen!**

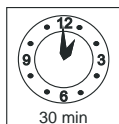
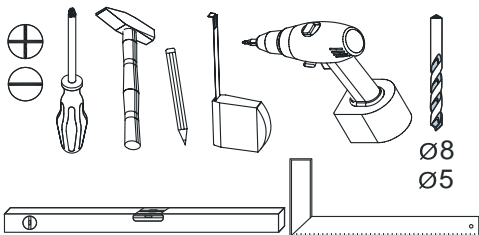

festziehen / tighten / Затягнете /  
 serrer / stringere / utåhnut / vasttrekken /  
 zategniti / stringere / zviazac / zacisnac /  
 szorosan meghúzni / pevne dotiahnut /  
 trdno pritegniti / затянуть / dra át



eindrücken / press in / enfoncer / wcisnac /  
 ribattere / zatlačit / Вкарайте / indrukken  
 benyomni / silacit / vtisniti / tryck in  
 introducere prin apăşare / вдавить



ausmessen / measure / mesurer /  
 misurare / opmeten / izmeriti / miara /  
 kimérni / izmeriti / măsurare / измерить  
 změřit / Измерете / mät upp / zmierzyc



drücken / press / presser / stisknout /  
 Натиснете / vtisniti / nasinac / drukken /  
 pritisnuti / nacisnac / pritisniti / нажать /  
 (meg)nyomni / apăşare / tryck fast / nacisnac



einschlagen / hammer in / beverni / slå in  
 frapper au marteau / infossare / Zabit' /  
 zarazit / Набийте / zabiti / wbić  
 introducece prin bătaie / забить / zatluoc



Drehen - wenden / przekrećić - odwrócić /  
 Keren - omdraaien / Girare - Ruotare /  
 Okrenuti - ubrnuti / Retourner - renverser /  
 Turn over - turn around / Otočte - obratite /  
 Завъртете - обвъртете / Obrnite list /  
 întoarceţi - rotiţi / Vríd runt - vänd /  
 прокрутитъ - повернитъ / otočit / obrátit  
 elforgatni - megfordítani

Modell name/Model name/Nom du modele/Modellnamn  
Nome modello/Název modelu/Modelnaam/Ime modela  
Numéro Modello/ Modell neve/ Название модели /  
Názov modelu/Ime modela/Denumire model/  
Наименование на модела /Nazwa modelu

**TIGO**

Type / Tipo / Tipus / Тип / Тип / Tip

**1D2S**

Farbe / Color / Couleur / Kolor

**EVOKE**

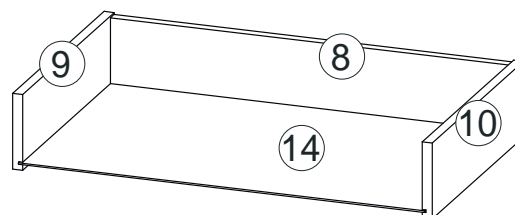
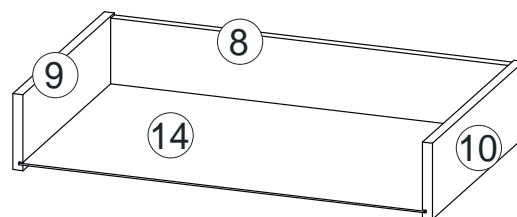
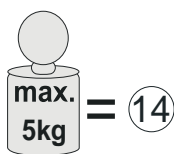
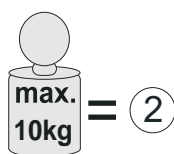
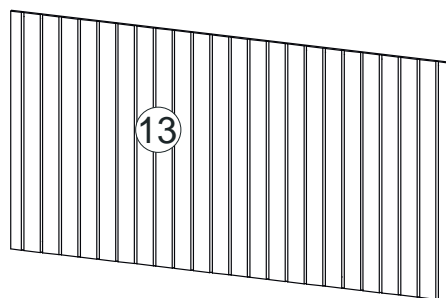
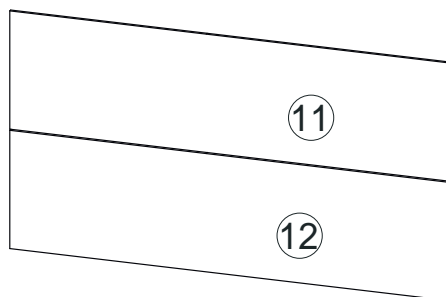
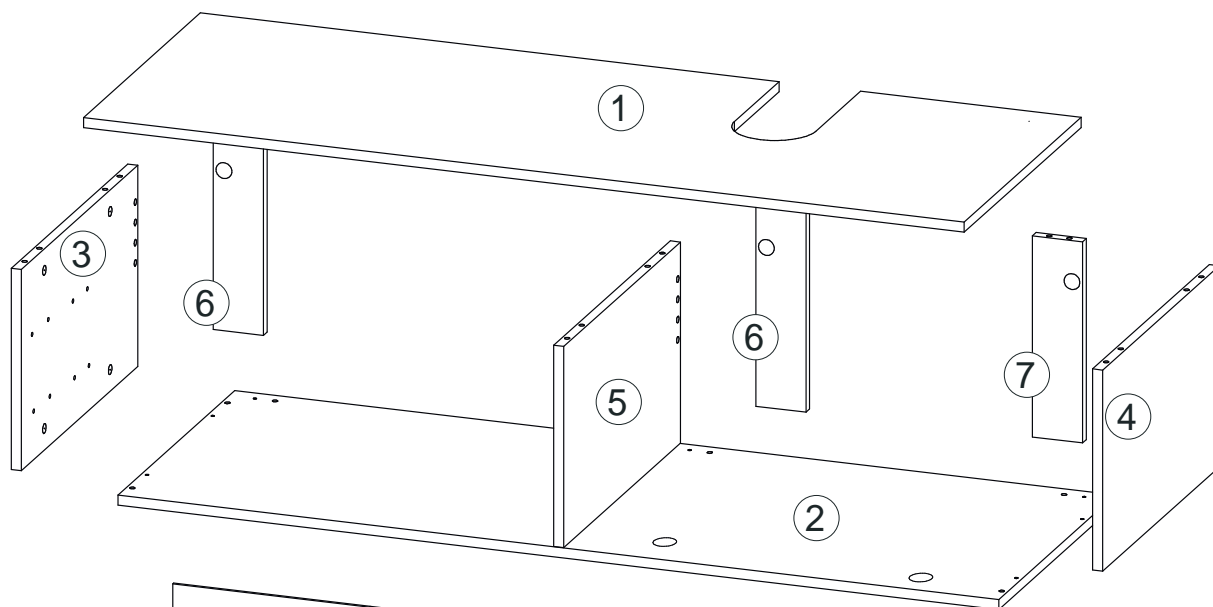

Nr.	Maße mm			Colli	Anzahl
1	1402	511	16	2/2	1
2	1402	511	16	2/2	1
3	318	510	16	2/2	1
4	318	510	16	2/2	1
5	318	510	16	2/2	1
6	318	80	16	1/2	2
7	318	80	16	1/2	1
8	636	104	16	1/2	2
9	400	120	16	1/2	2
10	400	120	16	1/2	2
11	698	187	16	1/2	1
12	698	187	16	1/2	1
13	376	698	16	1/2	1
14	646	404	2,5	1/2	2
B1				1/2	1

Modell name/Model name/Nom du modele/Modellnamn  
Nome modello/Název modelu/Modelnaam/Ime modela  
Numéro Modello/ Modell neve/ Название модели /  
Názov modelu/Ime modela/Denumire model/  
Наименование на модела /Nazwa modelu

**TIGO**











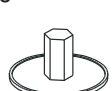
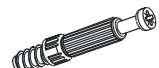

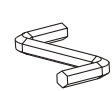

Type / Tipo / Tipus / Typ / Тип / Tip

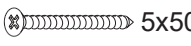
**1D2S**

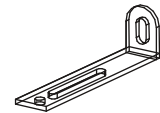
Farbe / Color / Couleur / Kolor

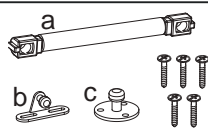
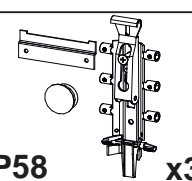
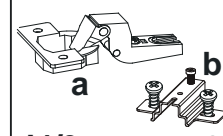
**EVOKE**

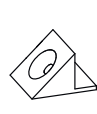
## B1

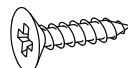
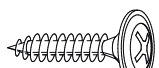
<p>Ø20</p>  <p><b>C0/11</b> x22</p>	 <p><b>C2</b> x22</p>	 <p><b>C7</b> x22</p>	<p>Ø12</p>  <p><b>B0/10</b> x8</p>	<p>6,4x50</p>  <p><b>B1</b> x8</p>	 <p><b>K</b> x1</p>
<p>Ø8x30</p>  <p><b>A0/1</b> x22</p>	 5x50  8x50 <p><b>E0</b> x8</p>	 <p><b>P0</b> x2</p>	<p>L-400</p>  <p><b>N16L</b> x2</p>	<p>L-400</p>  <p><b>N16R</b> x2</p>	 <p><b>F7</b> x1</p>
 <p><b>P58</b> x3</p>	 <p><b>J4/3</b> x2</p>	<p>5x13</p>  <p><b>D21</b> x16</p>	<p>L=610</p>  <p><b>R43</b> x1</p>	 <p><b>M1</b> x4</p>	<p>L-400</p>  <p><b>P24</b> x2</p>
<p>3,5x16</p>  <p><b>D5</b> x12</p>	<p>3,5x16</p>  <p><b>D36</b> x29</p>				

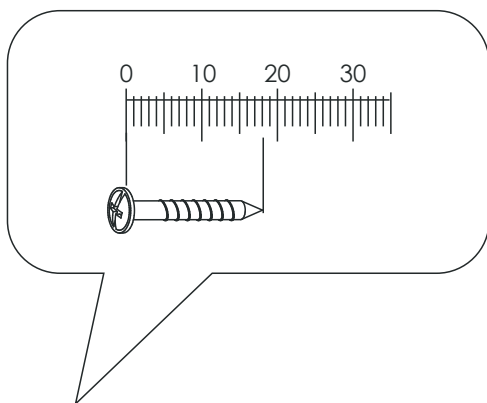

# 1

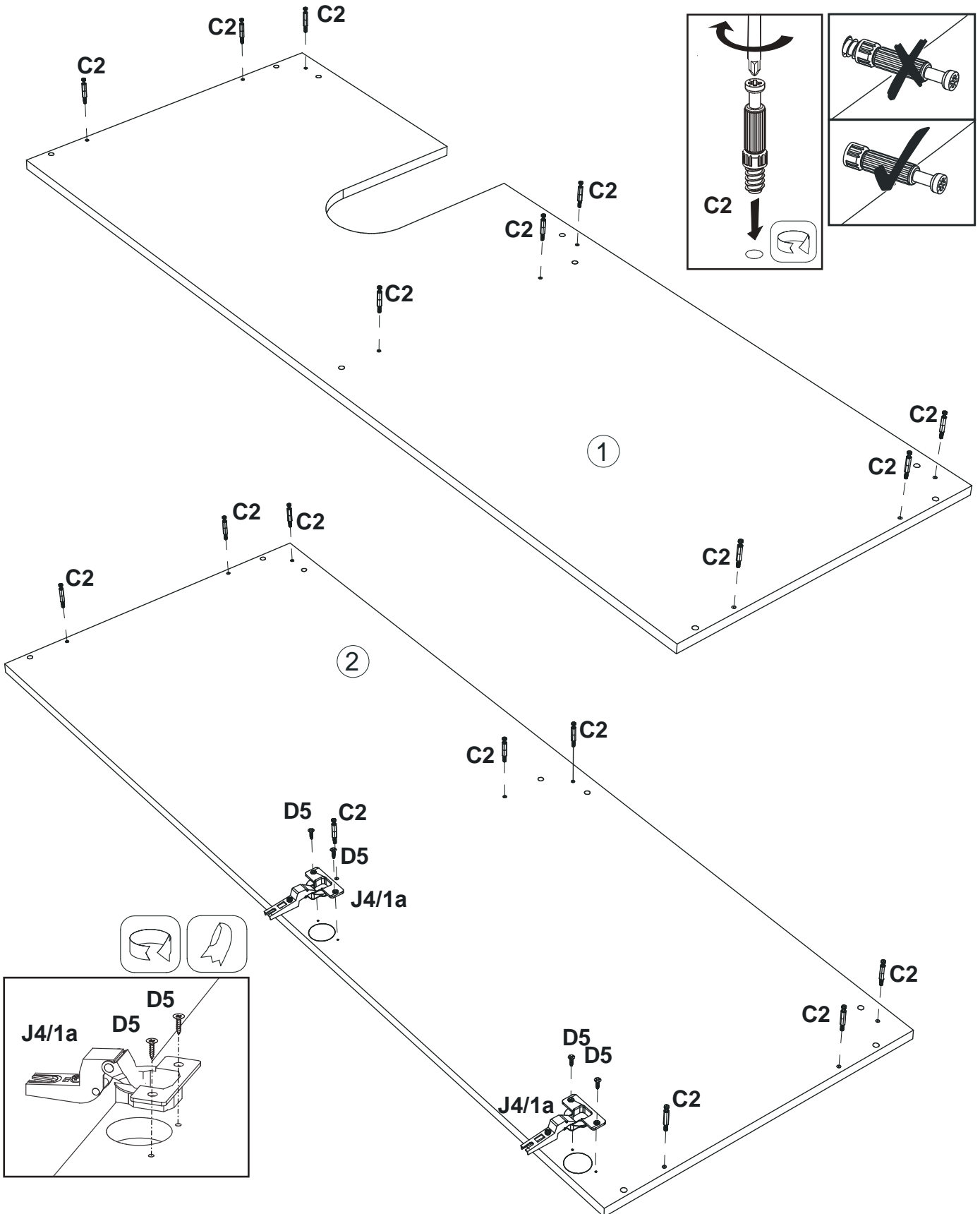
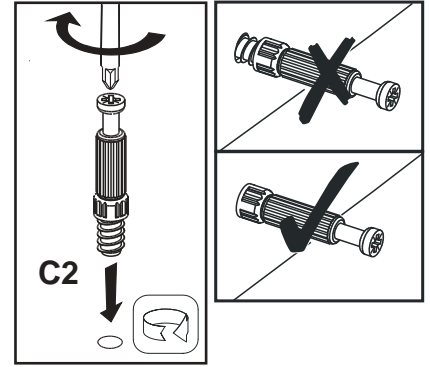
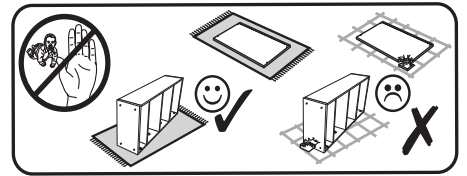
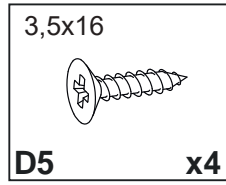
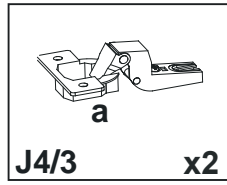
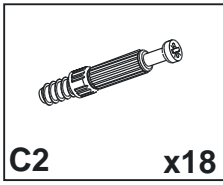

2

Ø8x30

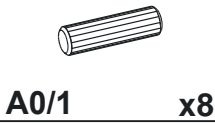

x8

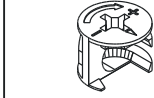

C7

x8

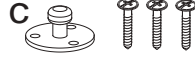

F7

x1

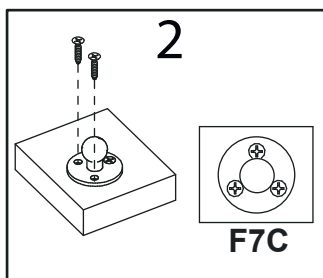
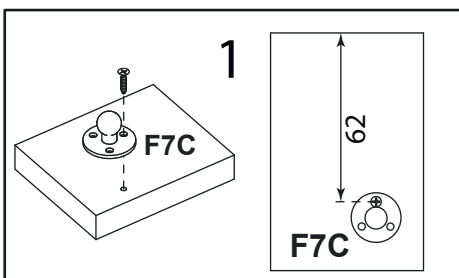
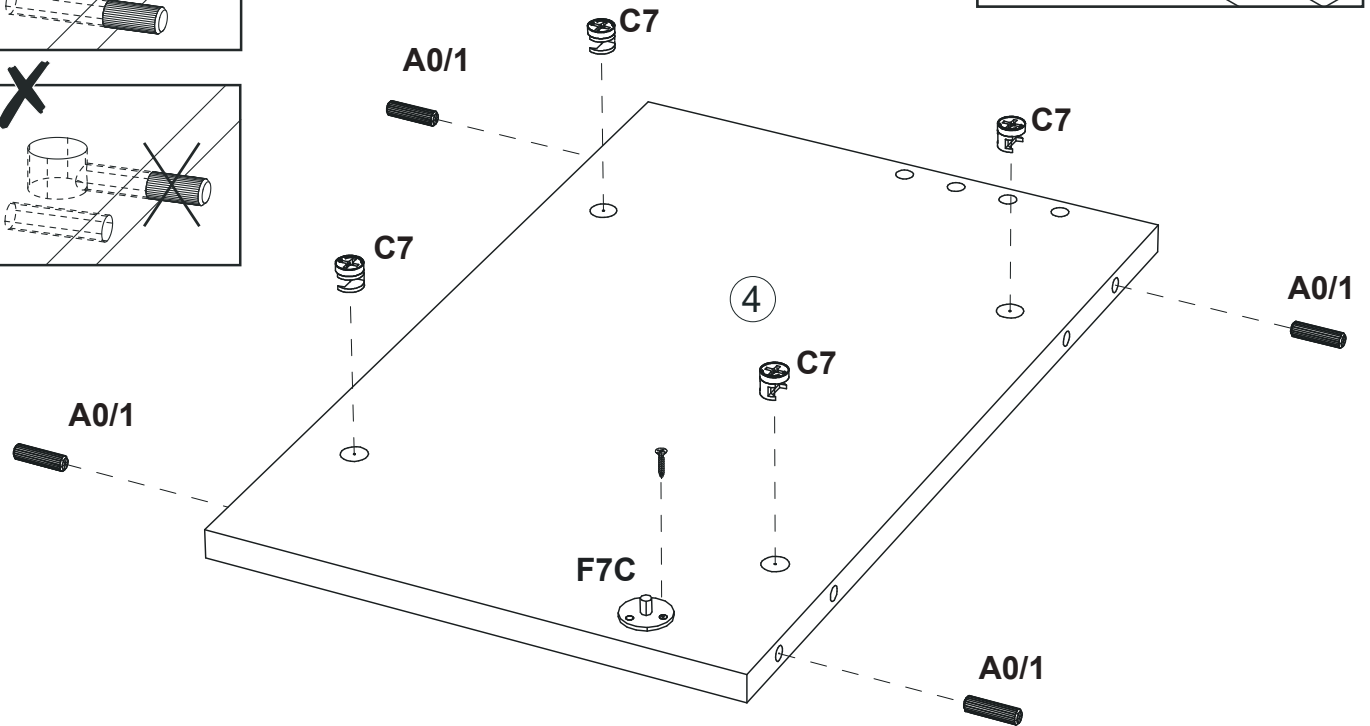
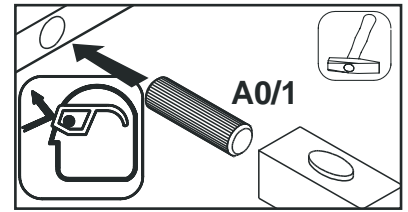
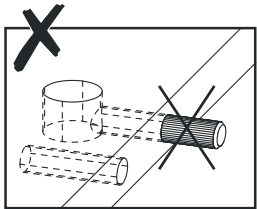
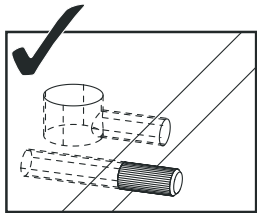
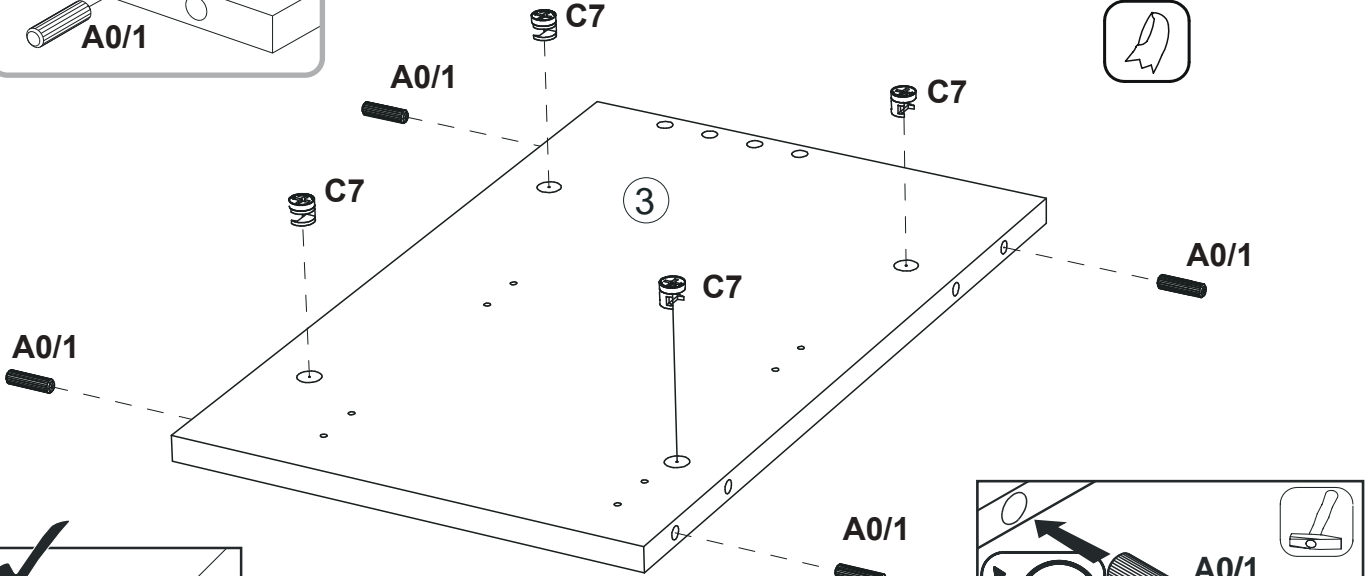
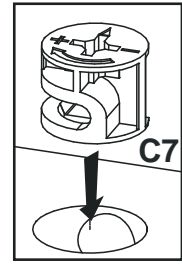
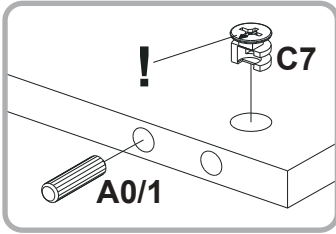

3

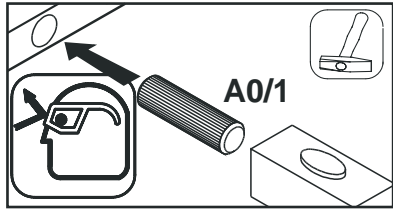
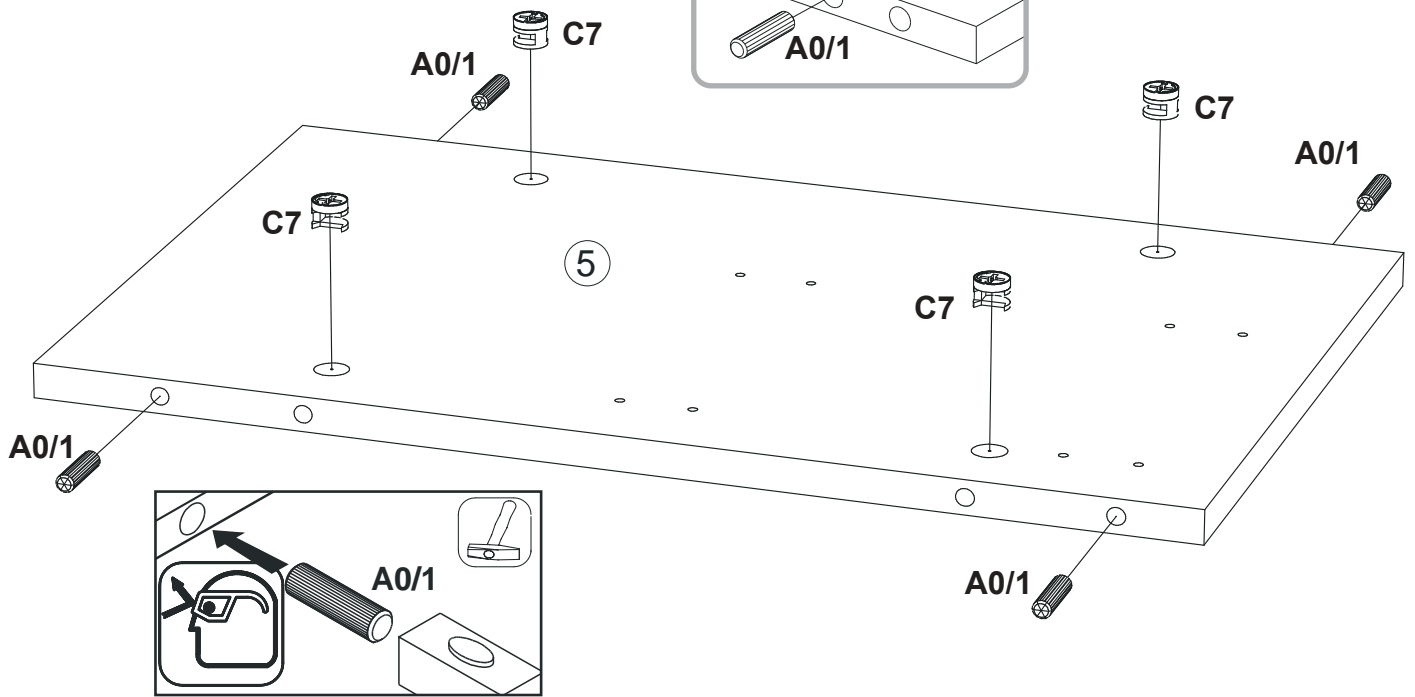
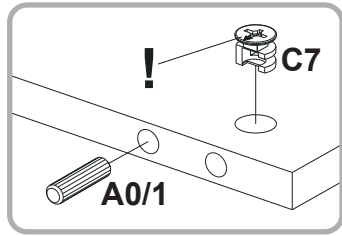
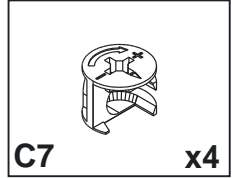
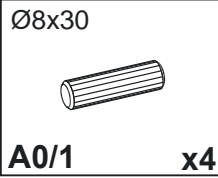

4

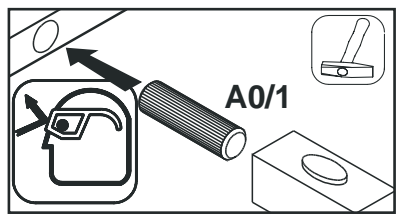
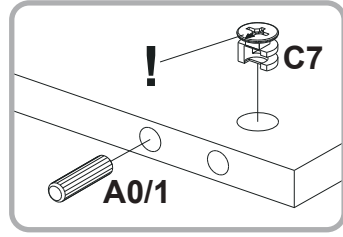
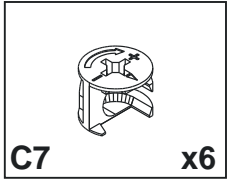
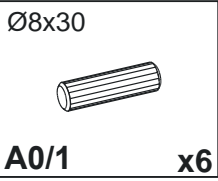

2x

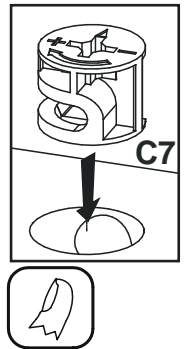
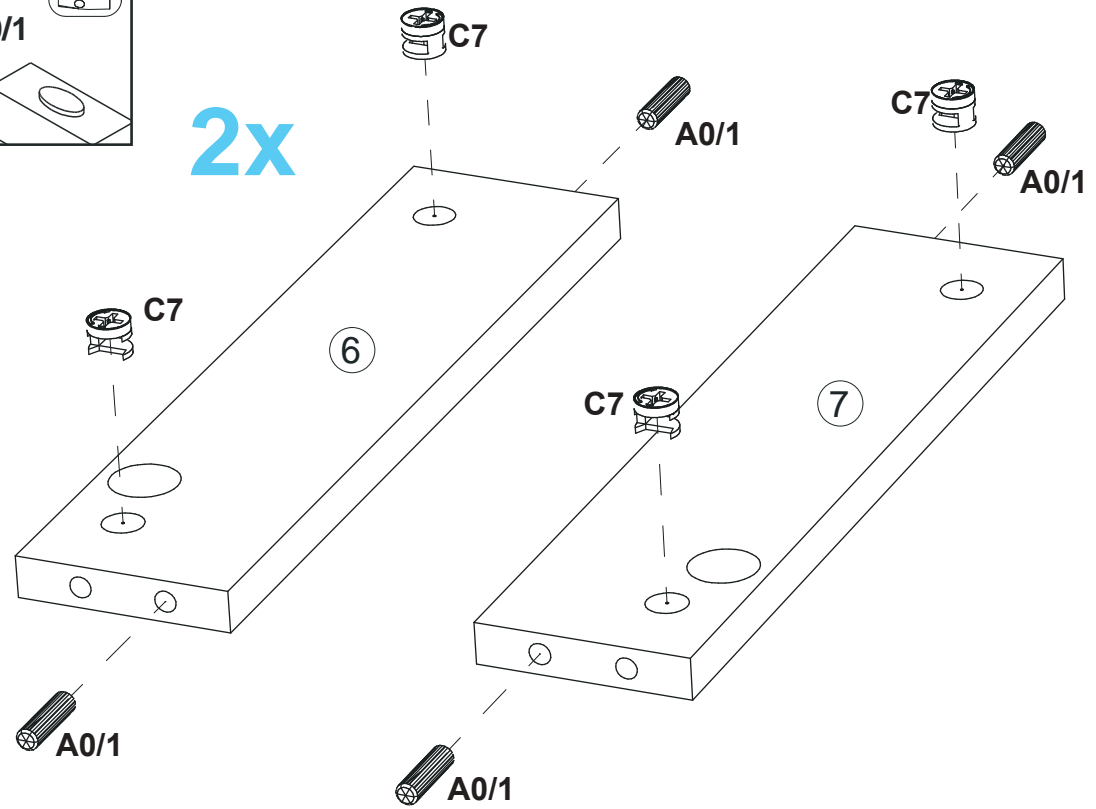

5

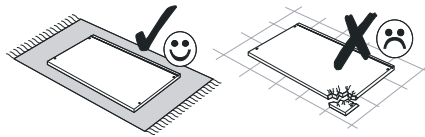
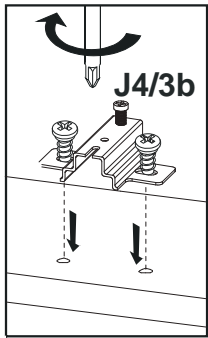
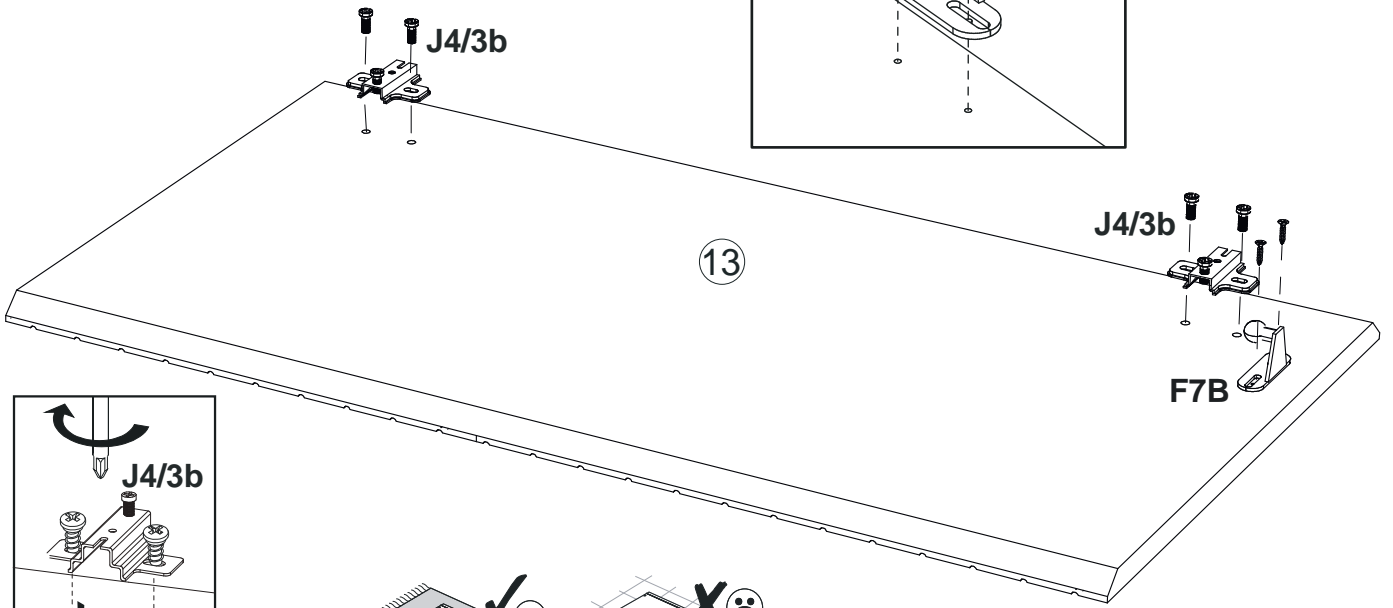
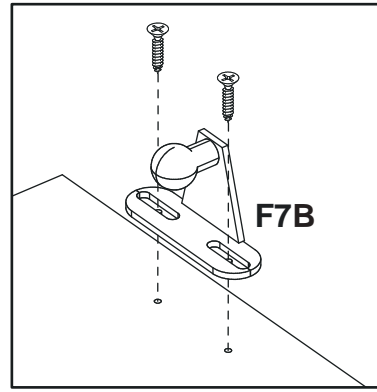
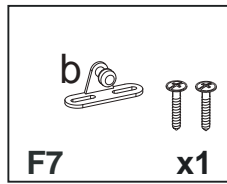
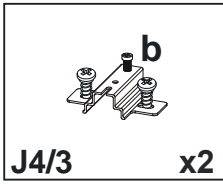

6

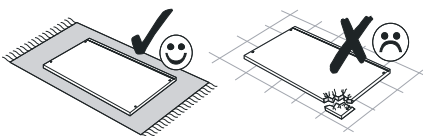
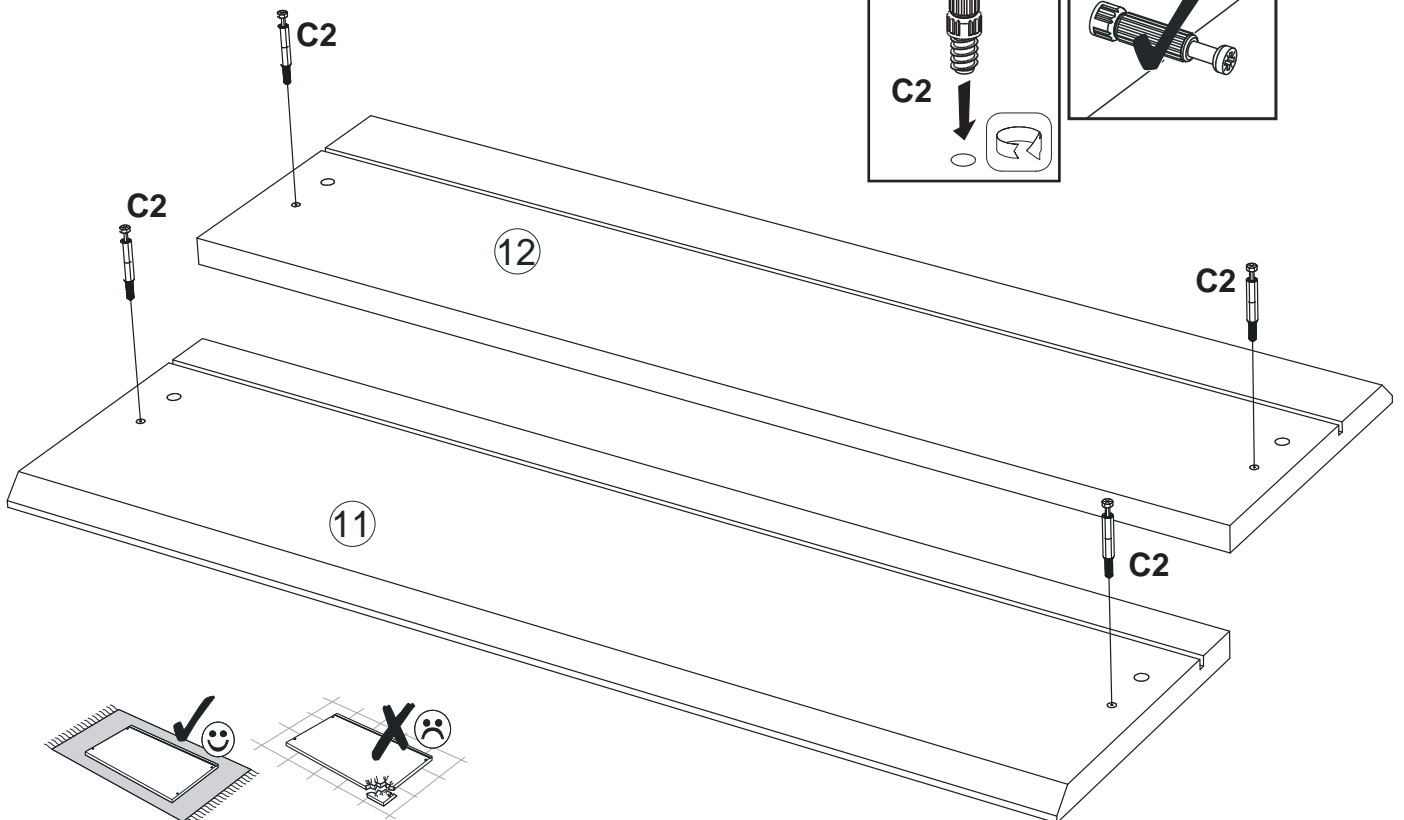
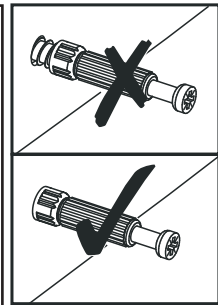
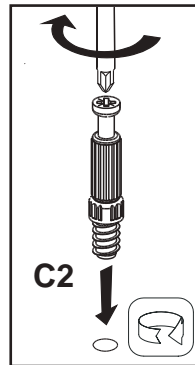
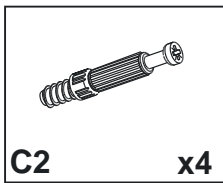

7

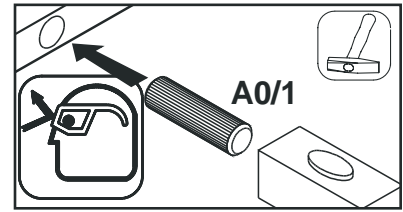
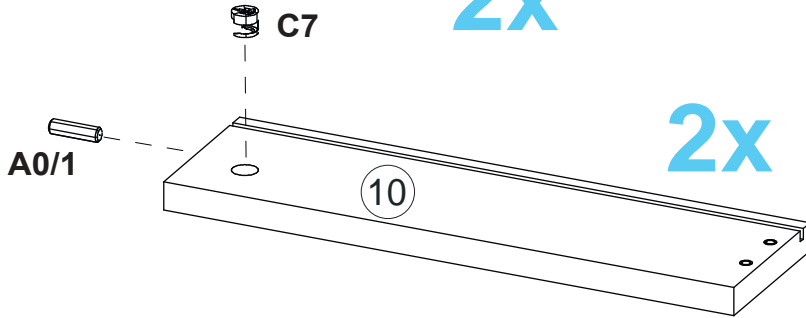
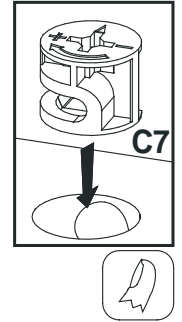
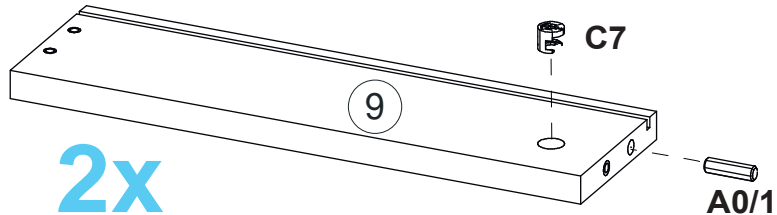
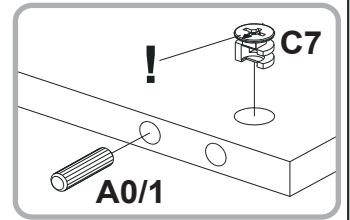
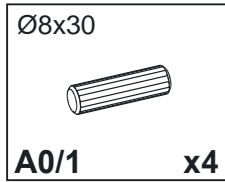
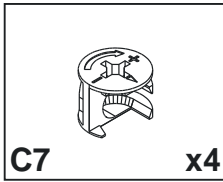

2x

2x

8

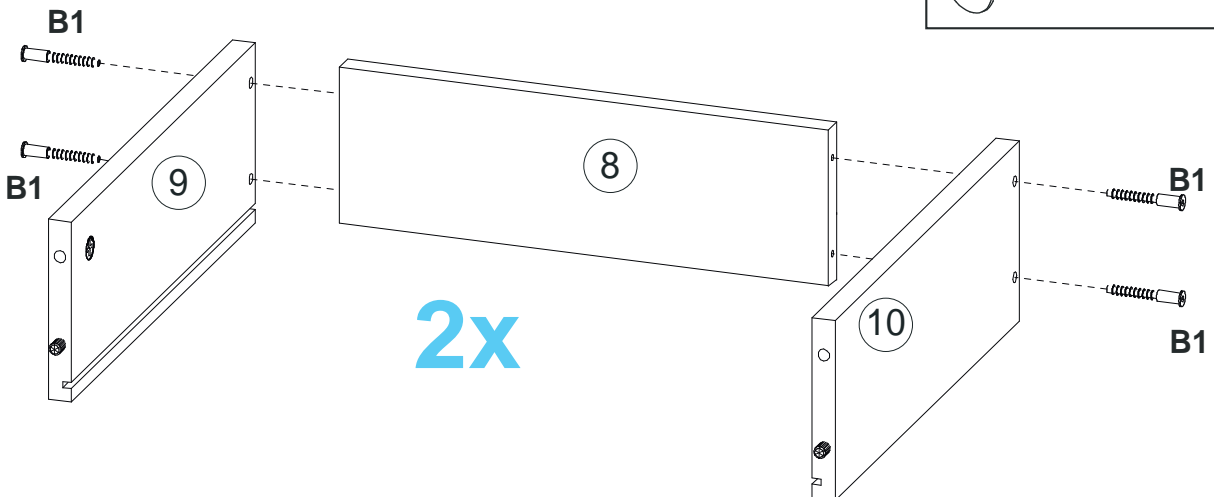
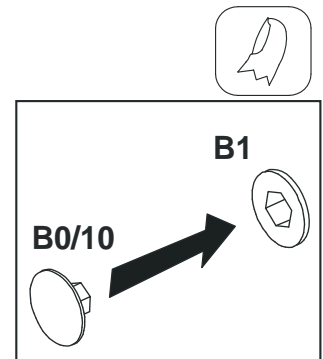
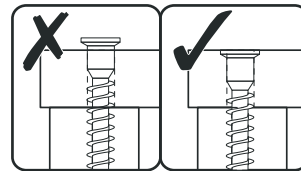
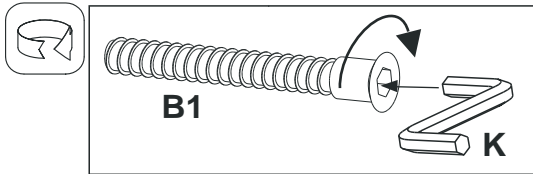
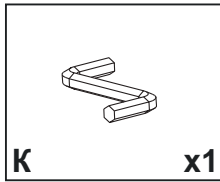
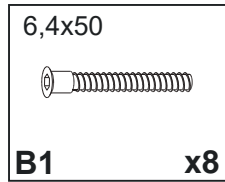
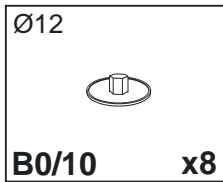

9

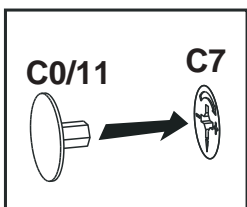
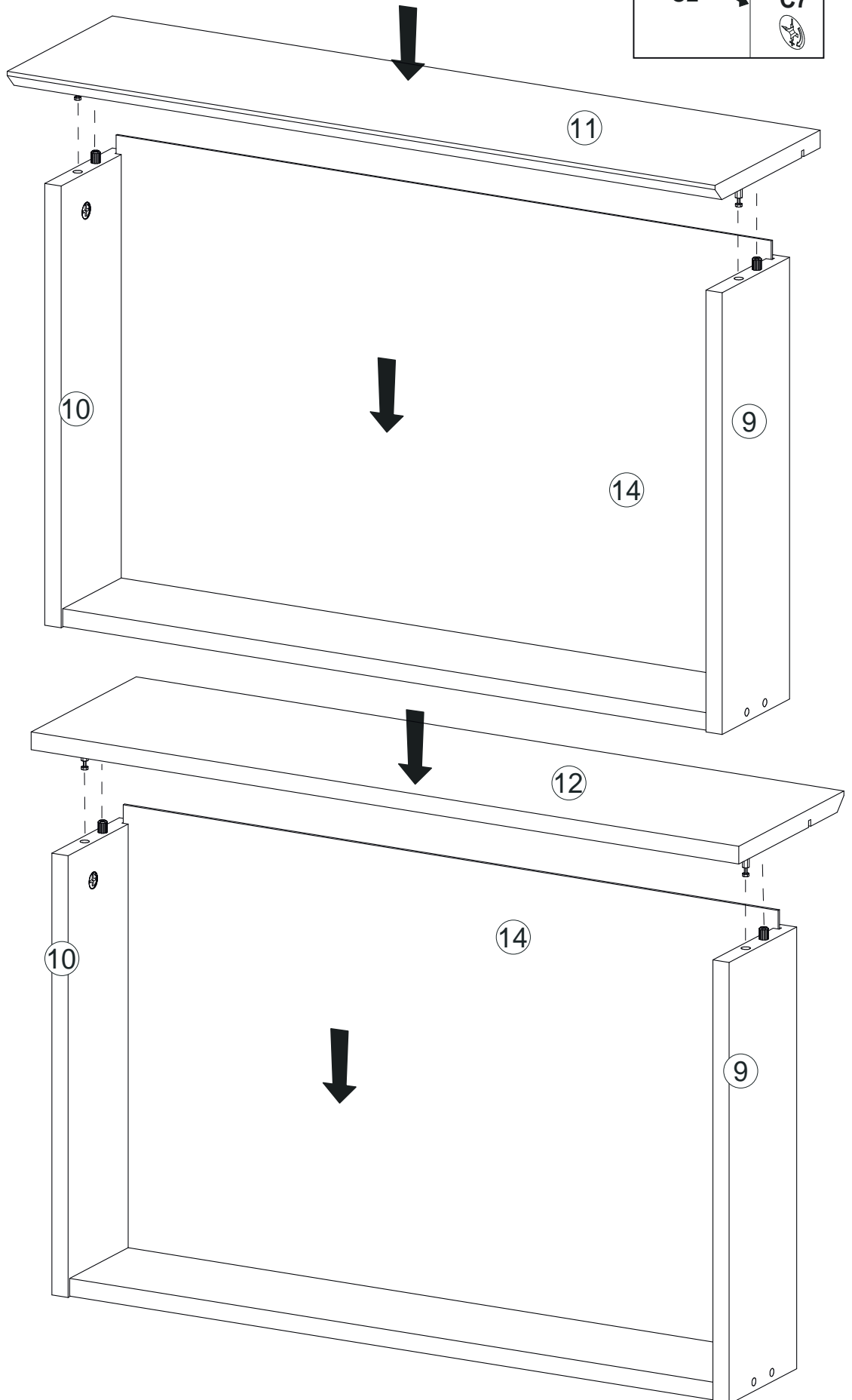
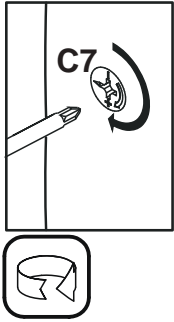
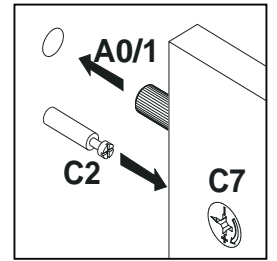
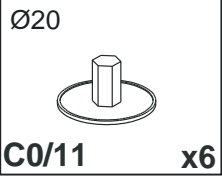

# 10

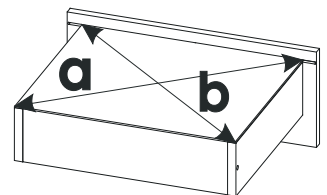
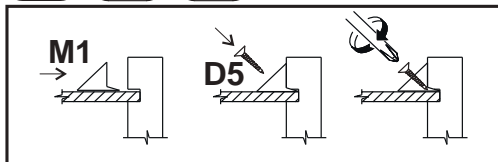
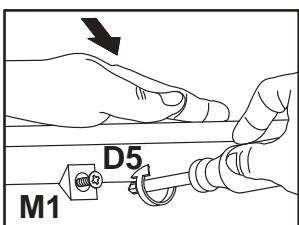
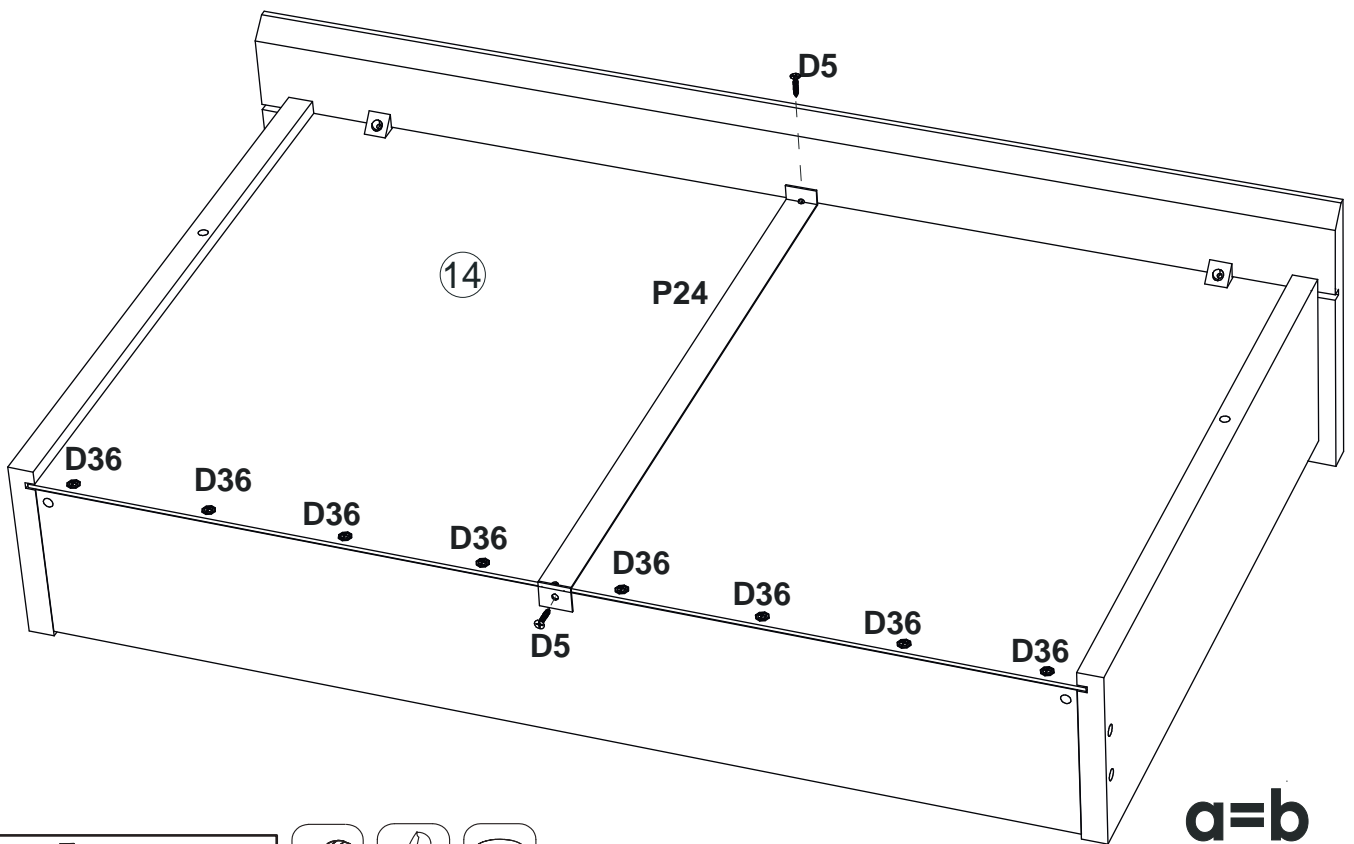
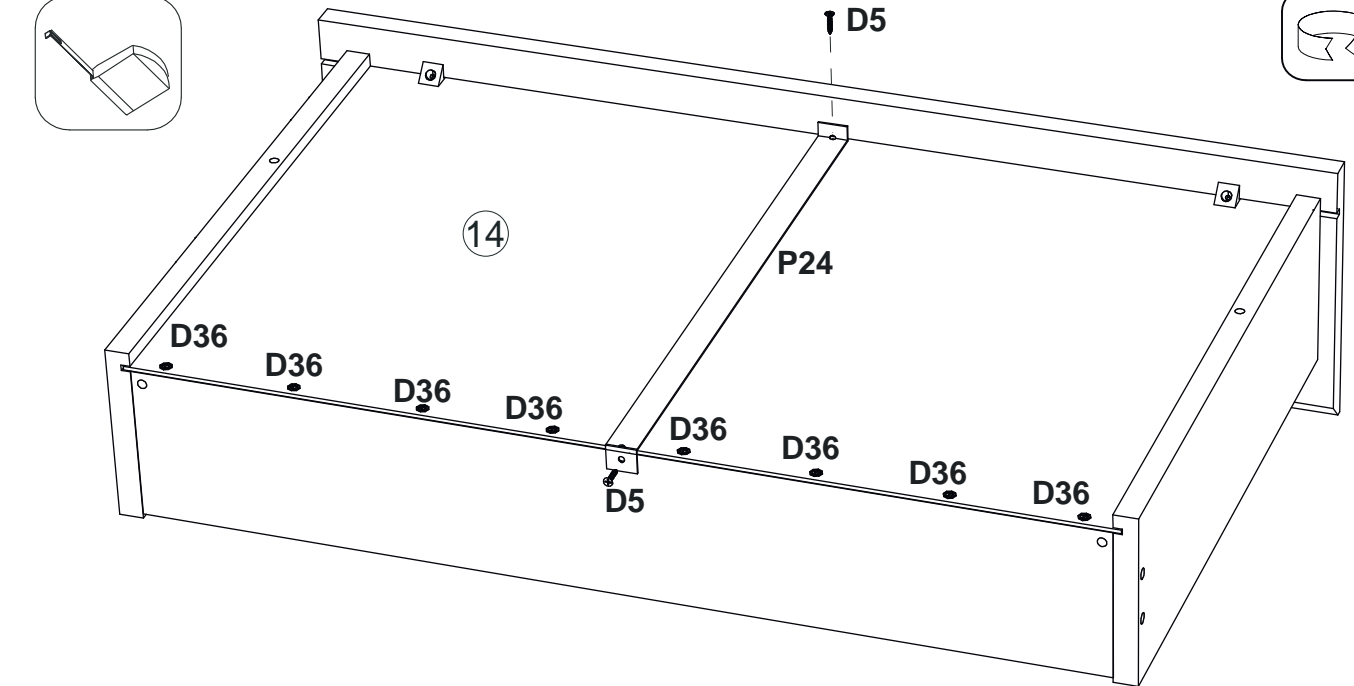
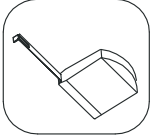
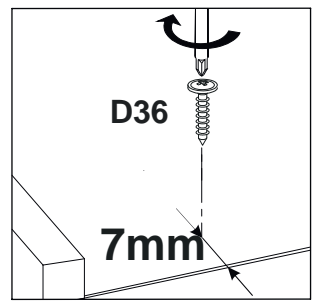
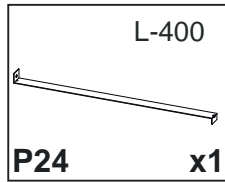
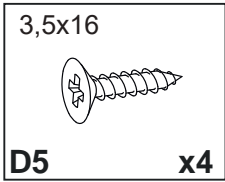
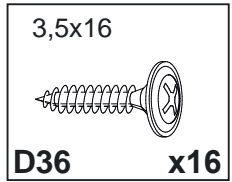
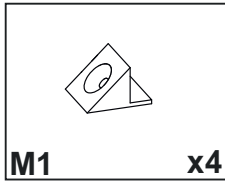

# 11

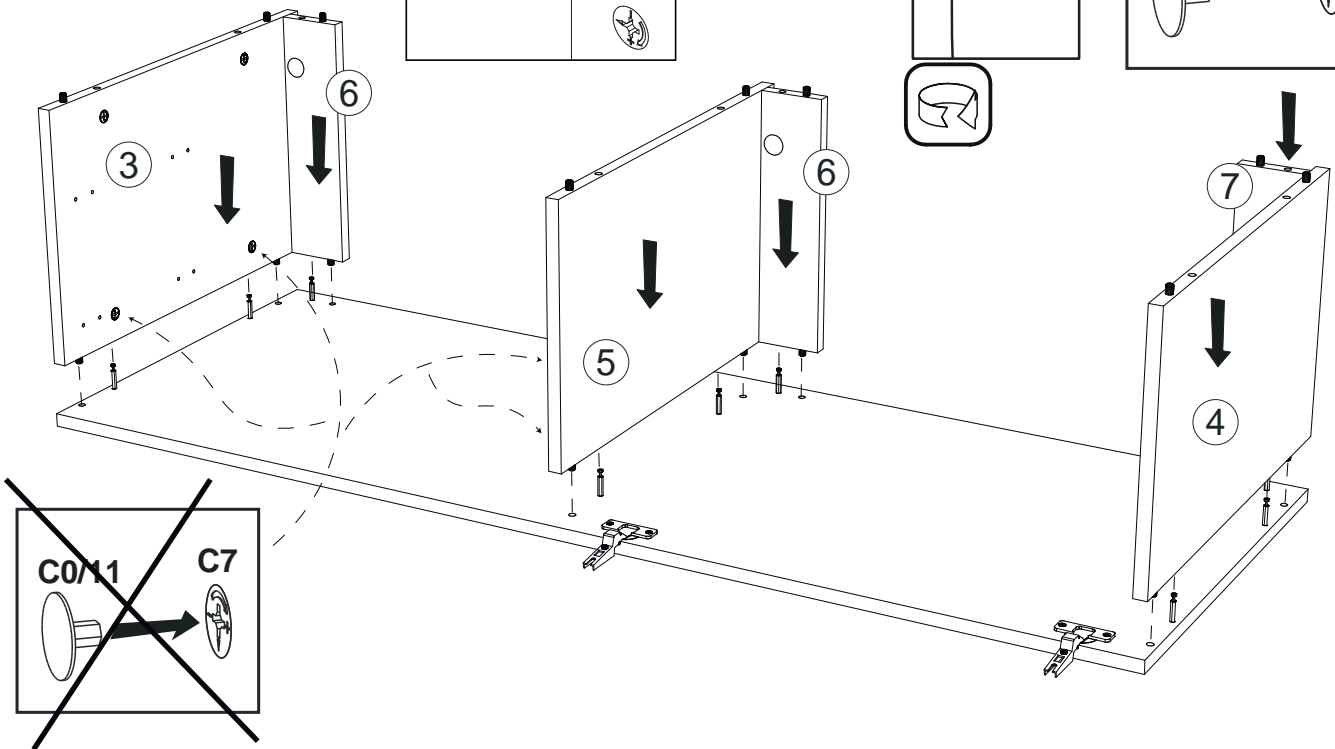
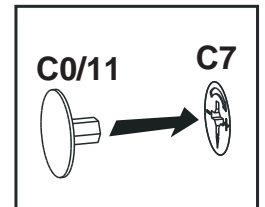
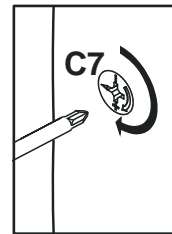
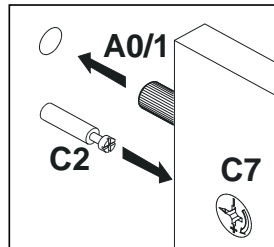
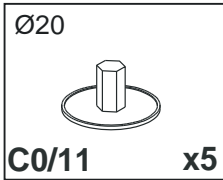

# 12

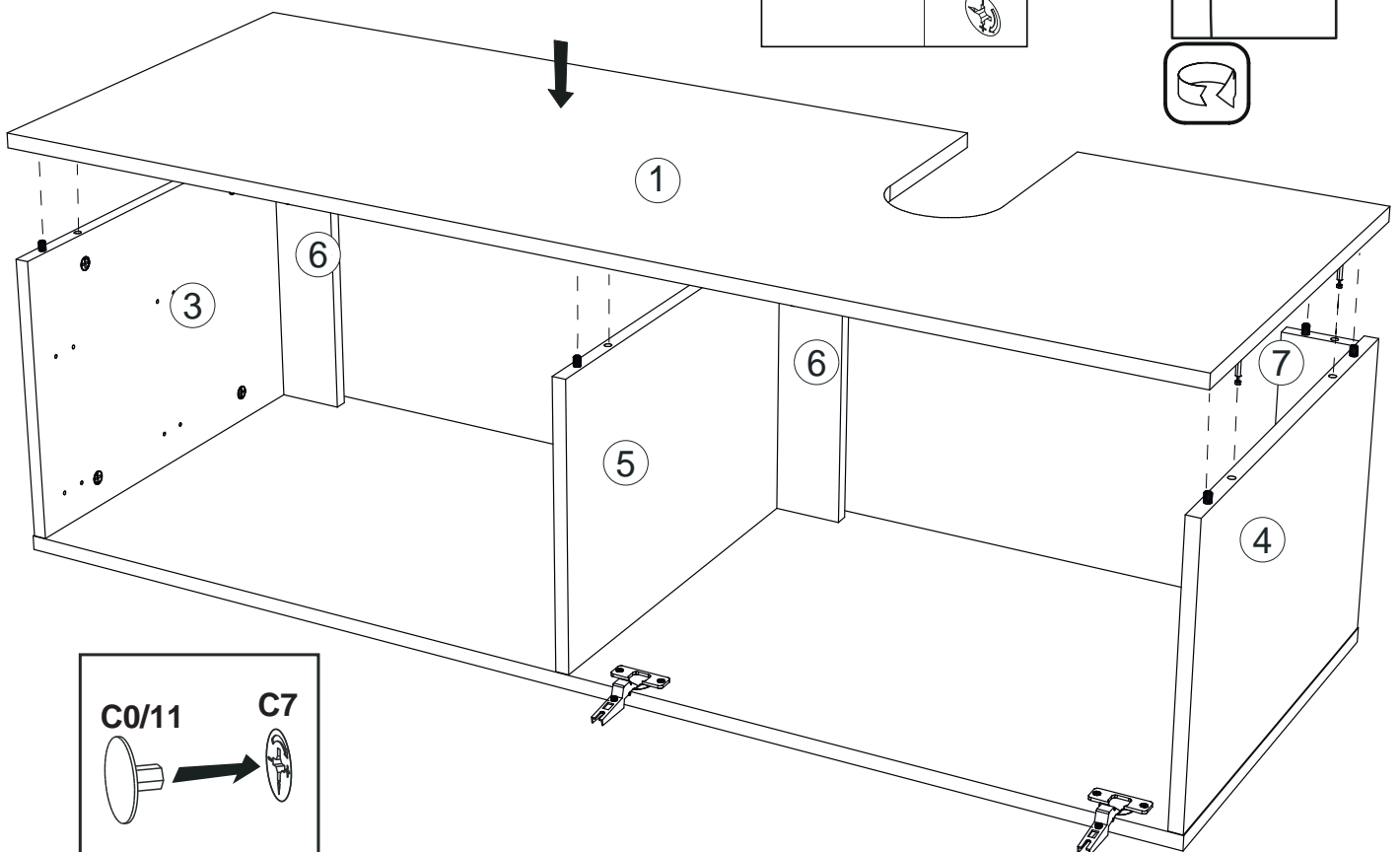
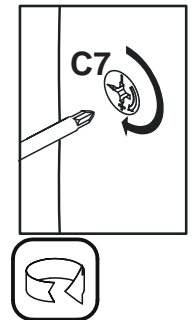
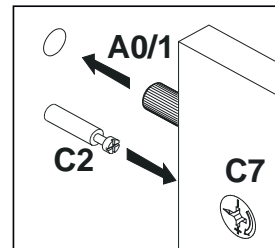
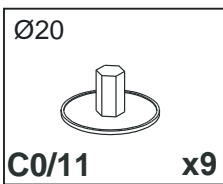

# 13

5x13  
D21 x12



L-400  
N16 x2

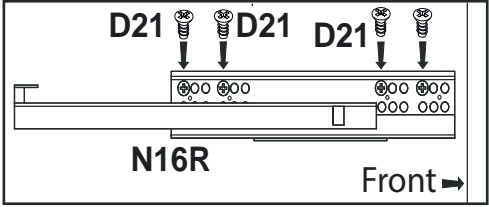
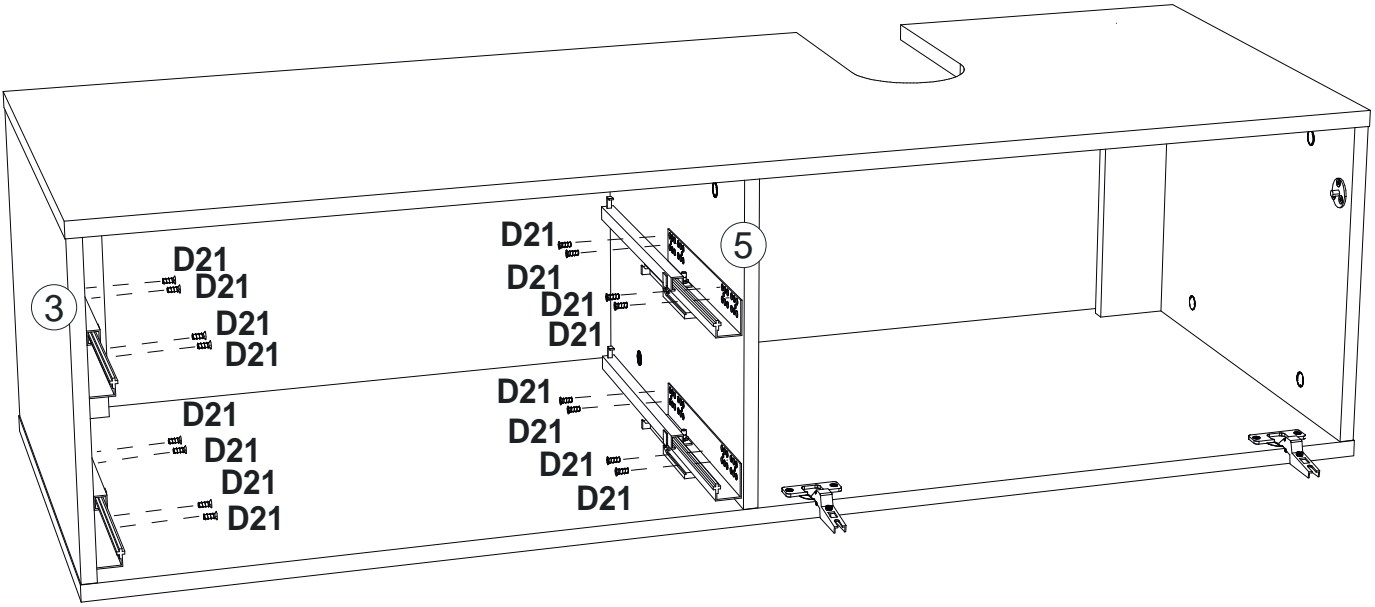
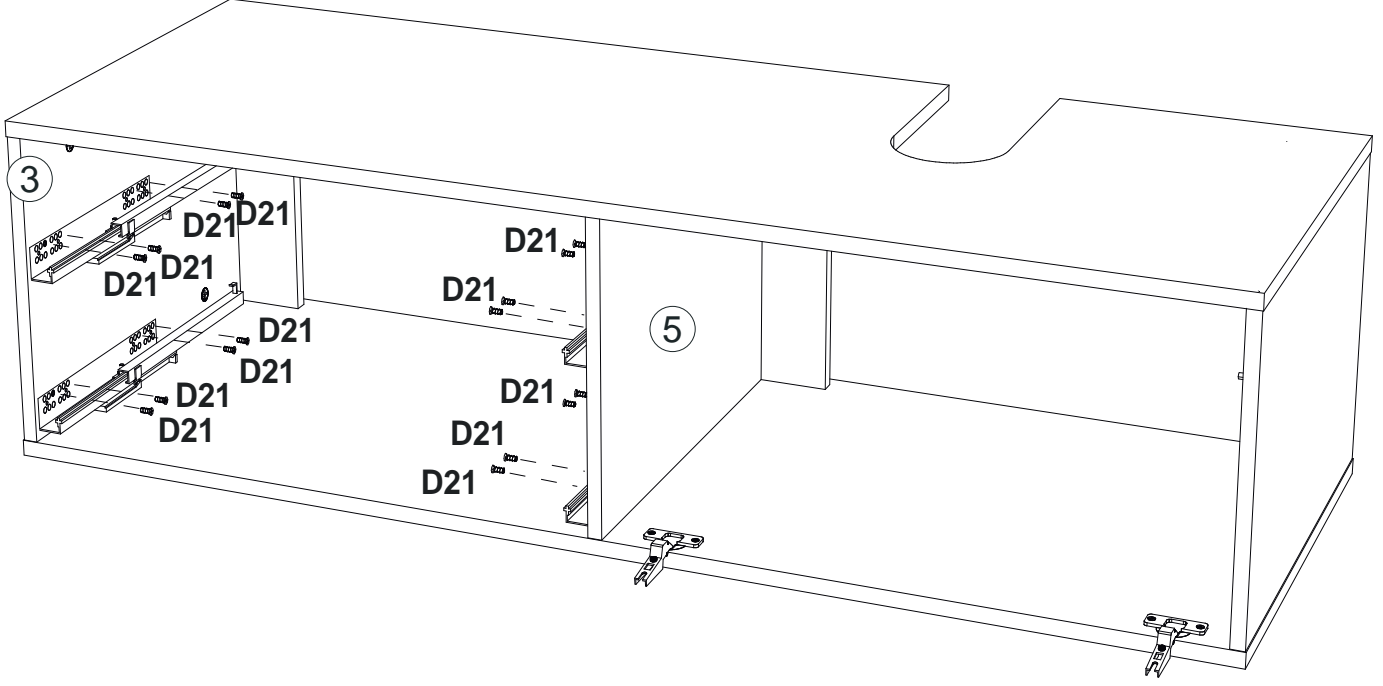
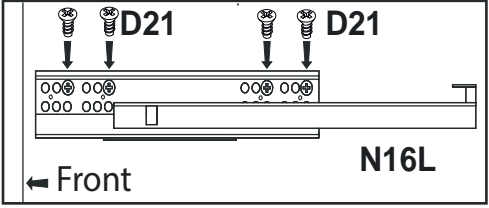
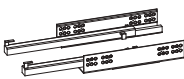

# 14

3,5x16

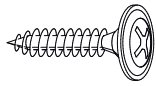

D36

x9

a

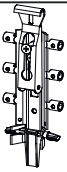

P58

x3

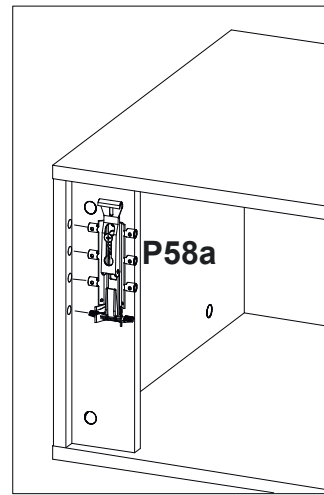

P58a

«I.»

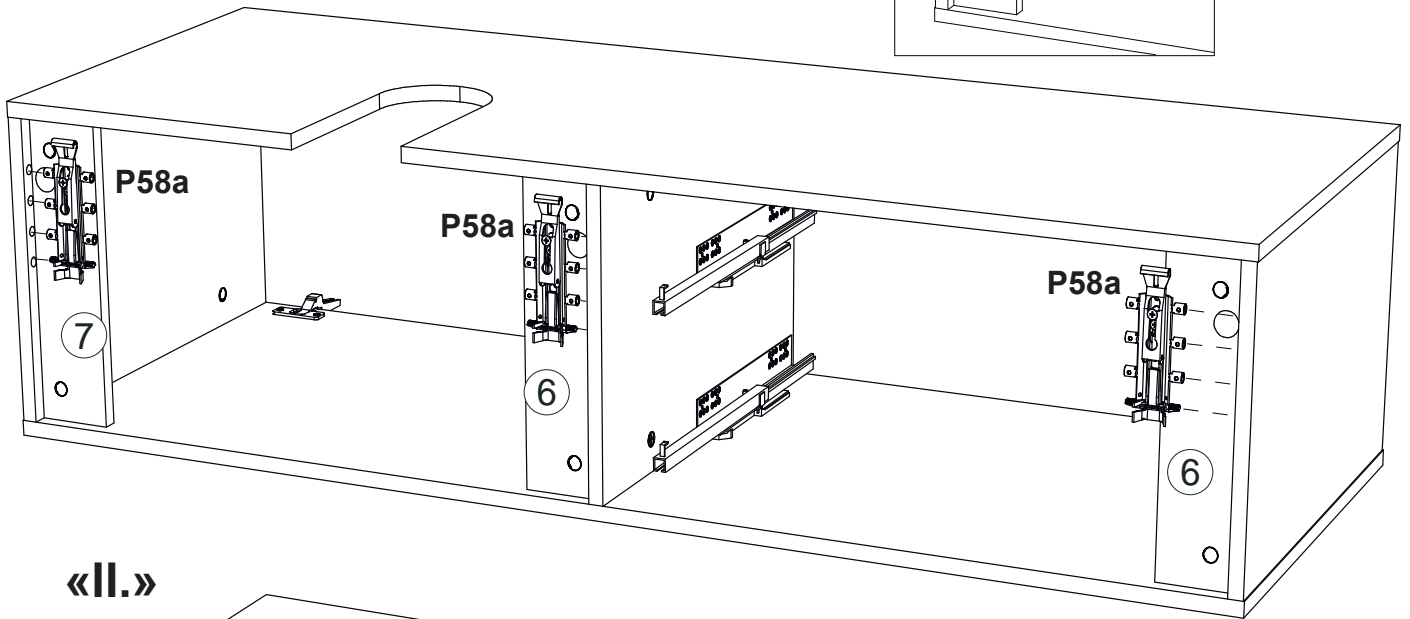

«II.»

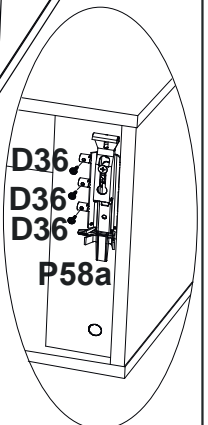
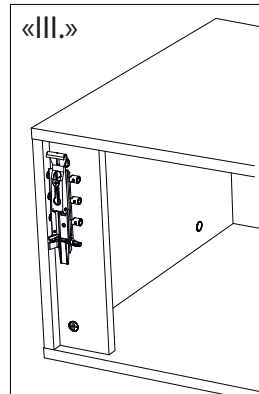
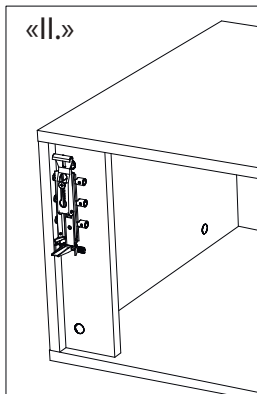
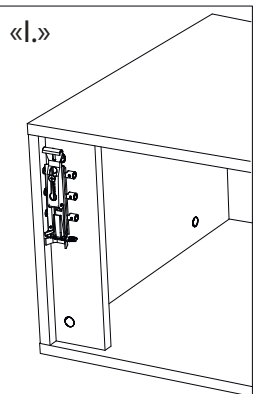
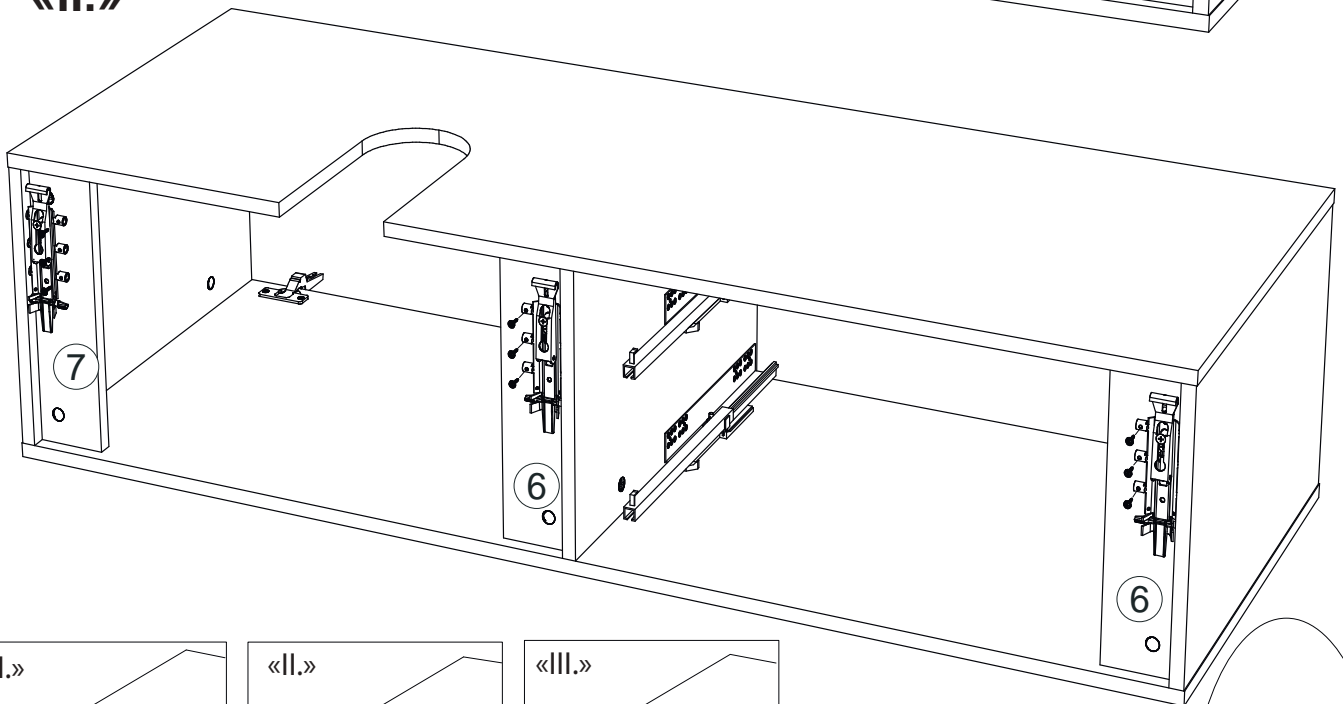

D36  
D36  
D36  
P58a

15

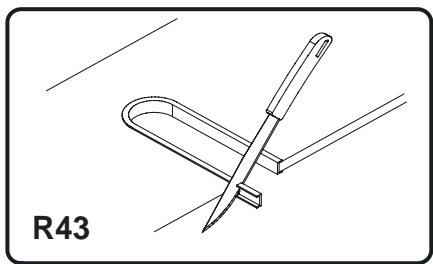
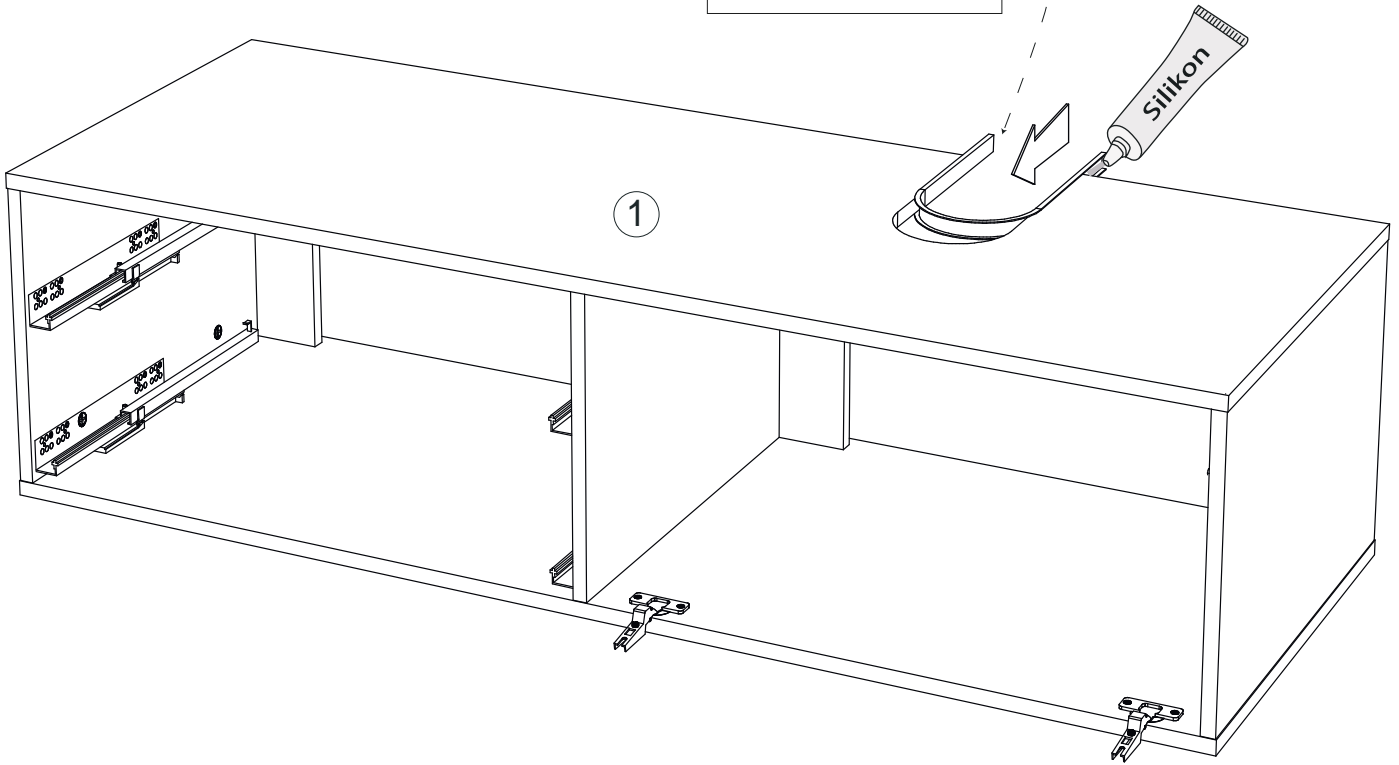
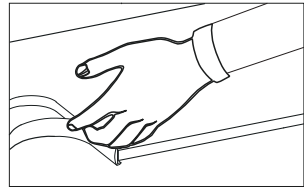
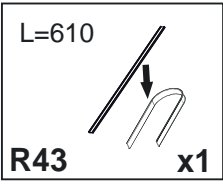

# 16

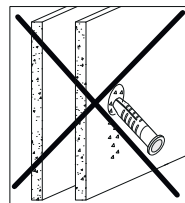
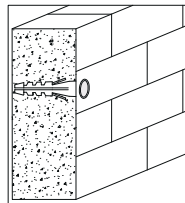
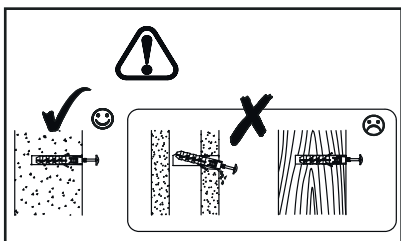
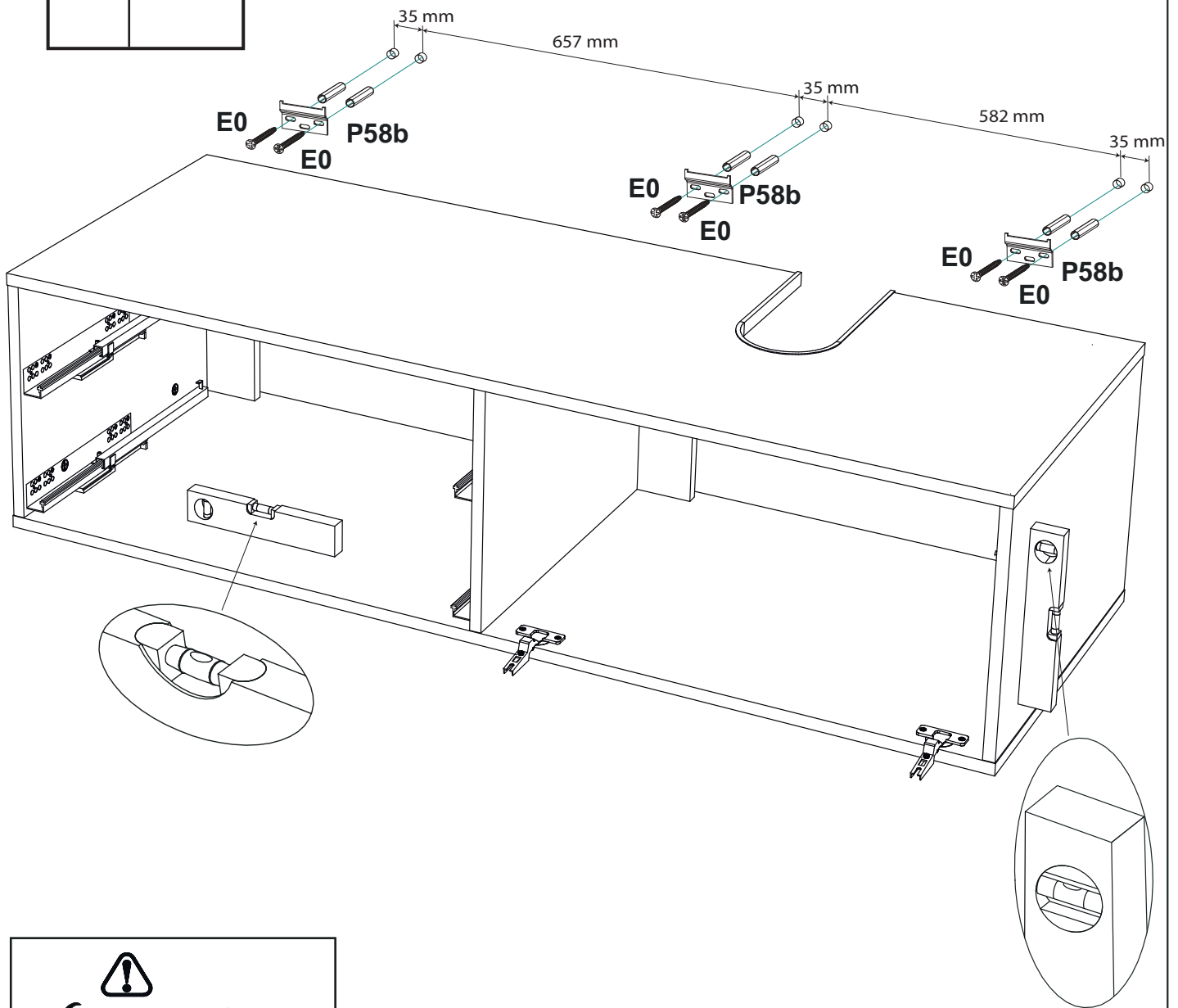
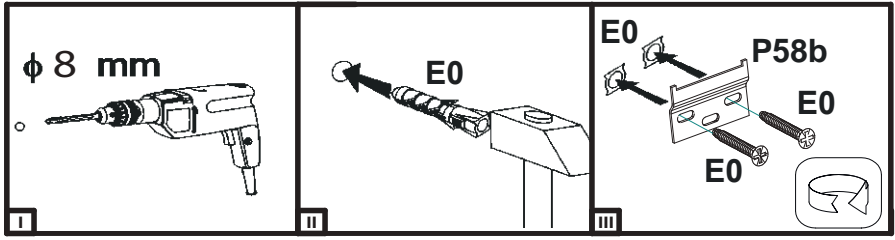
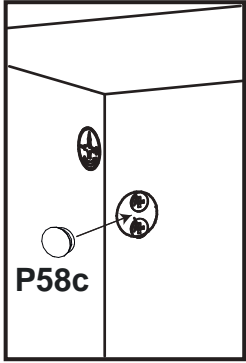
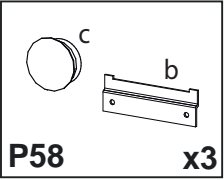
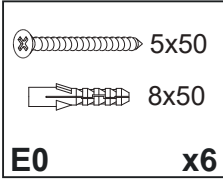

# 17

5x50  
8x50  
E0 x2

P0 x2

3,5x16  
D36 x4

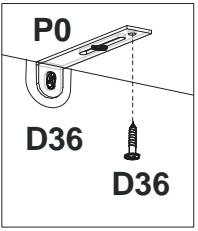
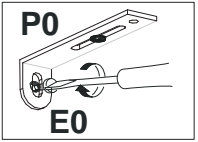
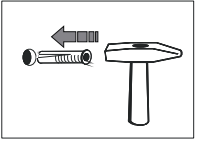
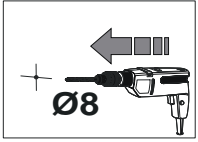
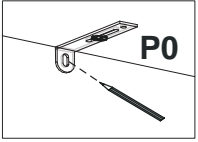
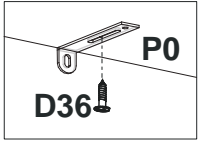
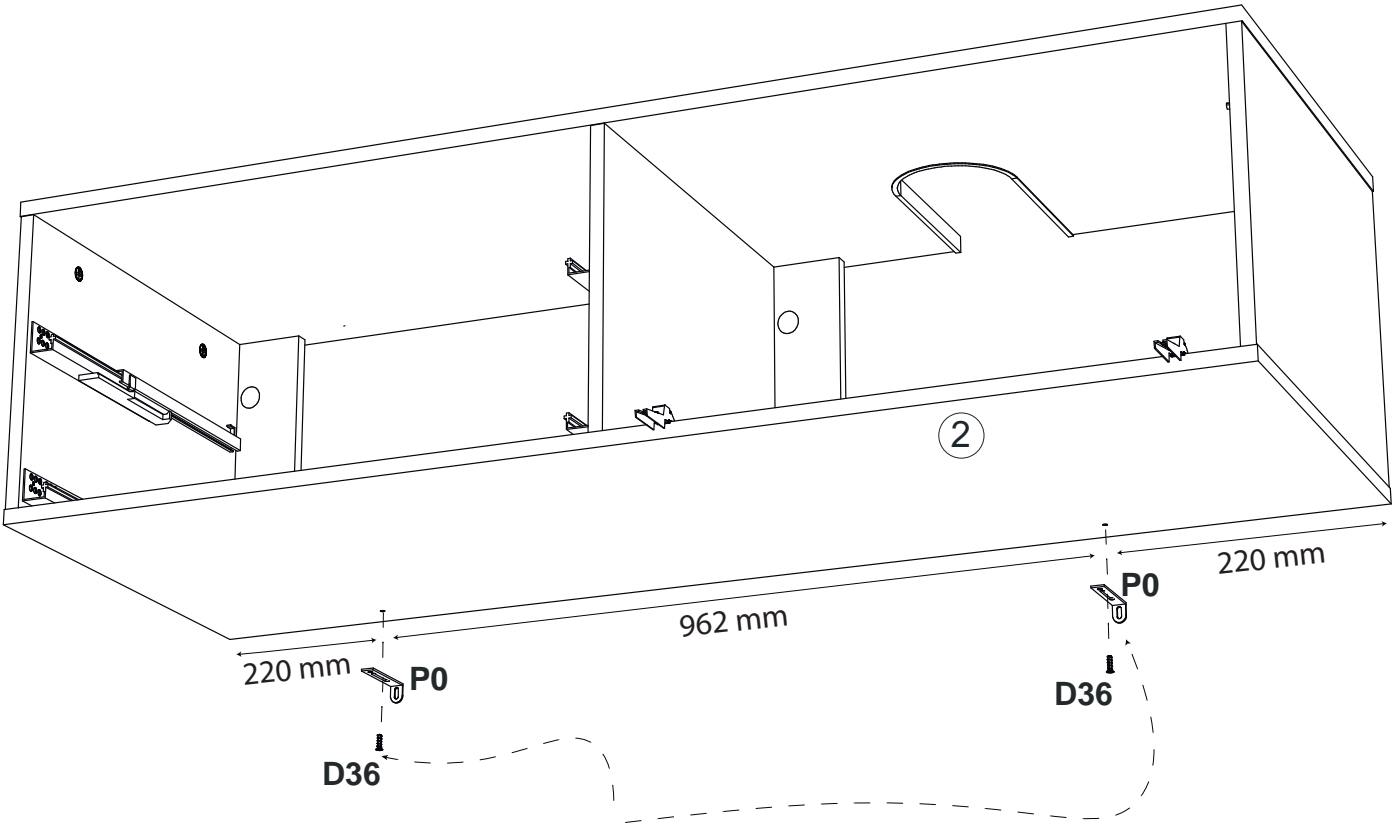
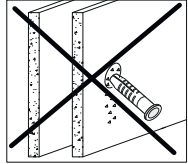
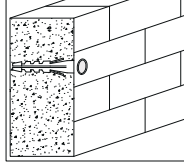
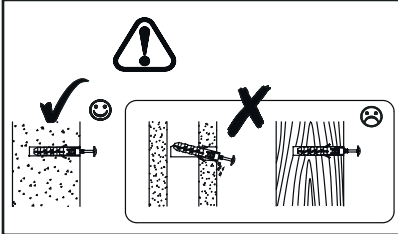

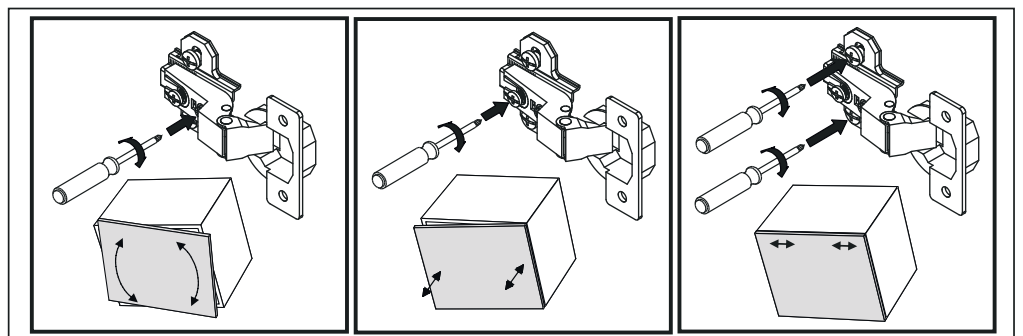
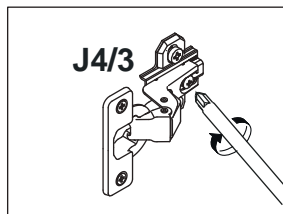
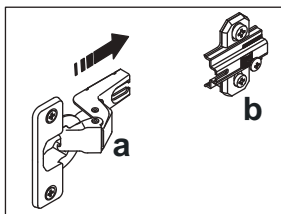
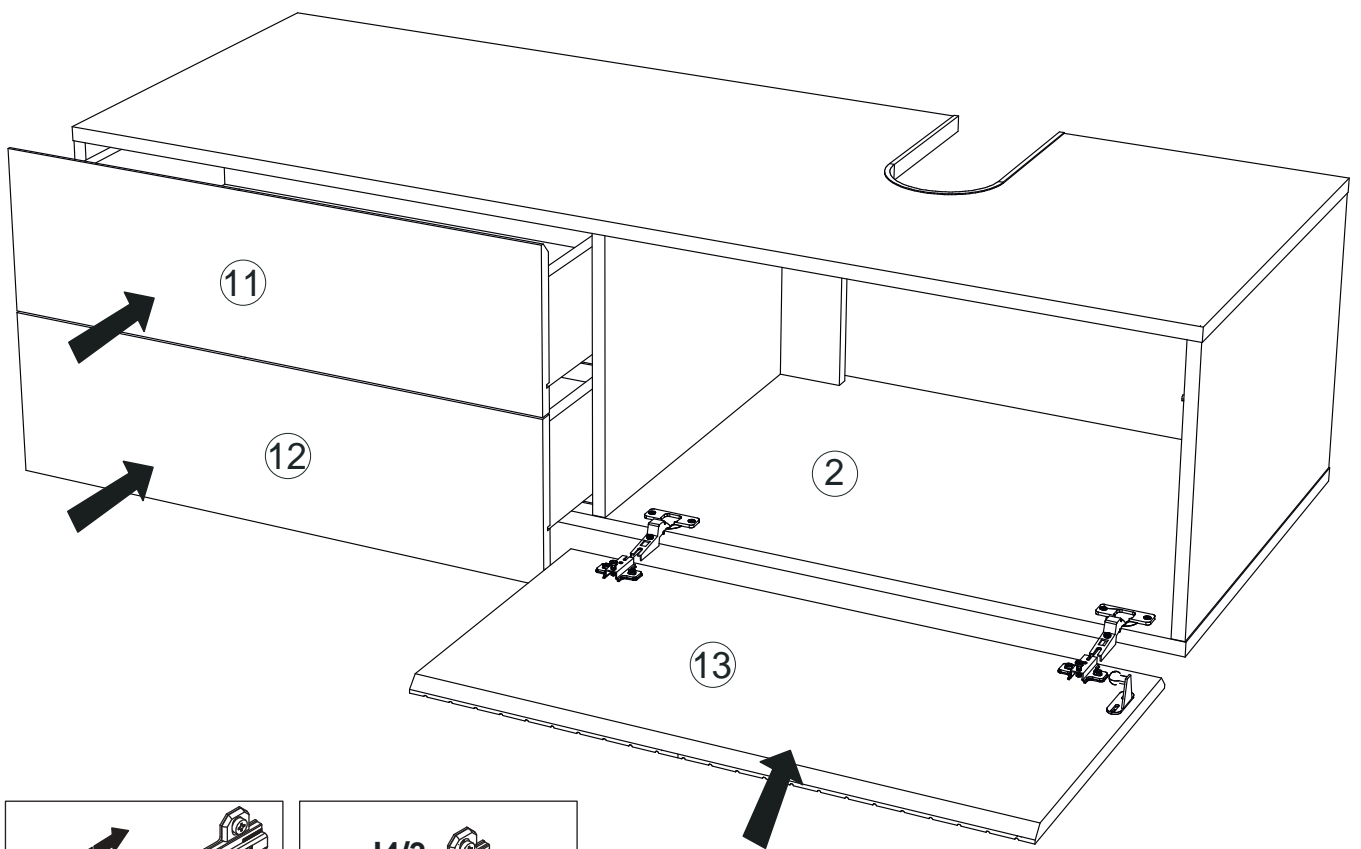
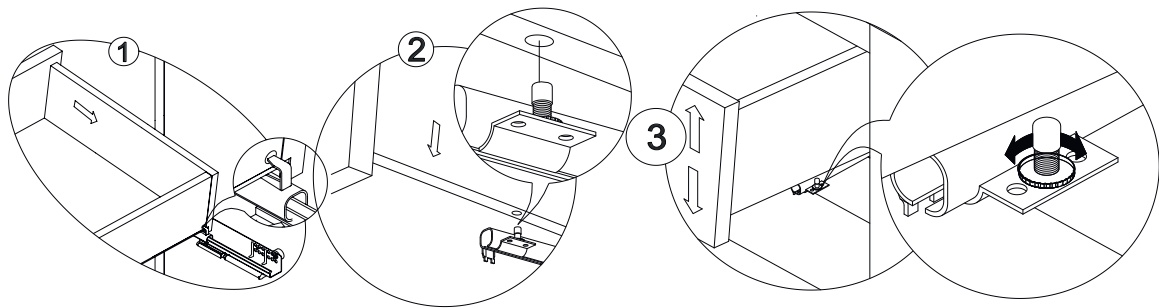

19

